

Logical Process Modeling of Spatio-Temporal Application

Aigong XU and Askey Harinda LAKMAL, China

Key words: logical model, spatio-temporal phenomena, concurrent process, π -calculus.

SUMMARY

Geographical phenomena involve entities and changes that are located in both space and time. Therefore, it is not an unjust germane to declare each geographical phenomena as spatio-temporal phenomena. As a result of that, building taxonomy of spatio-temporal phenomena implies an analysis of the representation of facts and occurrences within a space-time framework. While the absolute approach represents the space-time framework as a set or a collection of points and time instances, the relative approach has a view of mutual relationships between real world entities for this purpose. Spatio-temporal models deal with this so called relative approach. Those are crucial for performing assumption and predictions for physical, environmental, space and biological science. Typical application examples include traffic monitoring, regional ozone monitoring, disease mapping and satellite data analyzing.

This article addresses to the further development of Spatio-Temporal Process Model (STPM), which is from conceptual modeling phase up to logical modeling phase. This new model, which based upon concurrent processing and π -Calculus, stands for process oriented domain development and signal transmission between them. The logical modeling phase entirely developed by using the Real Time profile of Unified Modeling Language (UML) called UML-RT. So called profile also inherits UML artifacts such as designing, visualizing, constructing and documenting etc. The discussion about the modeling techniques in UML-RT and their applicability with the application of STPM also include in this paper. In the conclusion, the key issue that we encountered when modeling and further developments of this model also presented.

Logical Process Modeling of Spatio-Temporal Application

Aigong XU and Lakmal HARINDA, China

1. INTRODUCTION

The development of dynamic model on geographic information system with the spatio-temporal perspectives has been a long-term requirement in the scientific world since it represents the reality of the world. Navigational systems, natural hazards management and modeling of other natural phenomena are some typical examples of this emerging necessitate. Space and time are intrinsically tied to every aspect of real world phenomena is the reason for the aforementioned systems do exist. Although there were several valuable results for this necessitate from the research communities, only a few of among them were able to address successfully [Langran et. al 1988, Peuquet et. al 1995, Yuan 1996]. Our viewpoint is that every success result should use standard application design methodologies for its further development from conceptual level, while on the other hand such methodologies should be extended to accommodate the peculiarities of concurrent processing and real time signal transmission. But any successful result has developed neither up to execution level nor logical level yet.

The Spatio-Temporal Process Model (STPM) is a dynamic GIS model with the perspectives of spatio-temporal. The internal mechanism of STPM totally depends upon the concepts of π -Calculus [Milner 1999] and concurrent processing. Applications dealing with STPM fall in to one of four following categories.

- I) Application dealing on evenly changeable spatio-temporal phenomenon with location changes.
- II) Applications dealing on evenly changeable spatio-temporal phenomenon with attribute changes on a single location.
- III) Application dealing on unevenly changeable spatio-temporal phenomenon with location changes.
- IV) Applications dealing on unevenly changeable spatio-temporal phenomenon with attribute changes on a single location.

In all four cases, process modeling has been ruled uniquely for the temporal domain. Moreover, if any application deals with a combination of two categories (I and II or III and IV) that application is able to represent as a derived STPM. As an outcome of this STPM it is capable to retrieve status (situations) and transitions of spatial, temporal and spatio-temporal domains individually.

The aim of this paper is to develop the conceptual level STPM up to logical level as an extension of our earlier work [Xu et. al 2009] with the application of category I. According to our aforementioned viewpoint we have used standard logical modeling methodologies provided by the real-time profile on Unified Modeling Language (UML) called UML-RT

from Rational Software Company which is saturated on the peculiarities of concurrent processing and real time signal transmission. The Rational Rose Real Time (RoseRT) tools provide an extensive support for signal transmissions in process oriented and distribute systems. The concepts of π -Calculus are also known as mobility or signal transmission of process oriented systems. Therefore in our model development, we had to provide some modeling techniques of UML-RT communicating elements to π -Calculus. When providing modeling techniques, we made our total attentiveness to apply existing techniques in UML to minimize contradictions that can occur after introducing new techniques.

The rest of the paper is organized as follows: Section 2 brief description UML-RT profile and Section 3 reviews the conceptual mechanism of the STPM in the application of category I. The architecture of UML-RT for STPM which described in section 3 is presented in Section 4. Finally in Section 5 conclusions are drawn.

2. UML-RT PROFILE

UML-RT uses the UML built-in extensibility mechanisms to capture the concepts that have defined by the Real-time Object Oriented Modeling (ROOM) Language [Selic et. al 1994]. UML-RT is not meant to annotate a design model with information allowing for quantitative analysis, just like the two previous profiles, UML profile for schedulability, performance, and timing (UML/SPT) and UML profile for Quality of Service (UML/QoS). It has its own modeling capabilities. UML-RT allows the designer to produce models of complex, event-driven and possibly distributed real-time systems. It provides two modeling systems called structural and behavioral for a real time system [Gherbi et. al 2006].

2.1 Structural Modeling

UML-RT provides the designer with entities called capsules, which are communicating active objects. The capsules interact by sending and receiving messages through interfaces called ports. Furthermore, a capsule may have an internal structure composed of other communicating capsules and so on. This hierarchical decomposition allows the modeling of complex systems.

2.2 Behavioral Modeling

Behavior is modeled by an extended finite state machine which is visualized using UML state diagrams. These state machines are hierarchical since a state could be decomposed into other finite state machines. A message reception triggers a transition in the state machine. Actions may associate with transitions or the entry and/or the exit of a state. Order or the sequence of messages is modeled by sequence diagram.

The main target application domain of UML-RT is telecommunication systems, which are generally soft real-time in nature. Perhaps due to this reason, the designers of UML-RT have not put much emphasis on real-time issues when implementing a UML-RT model on the target platform. The default execution model is single-threaded, that is, all capsules are

mapped into the same thread of execution. Messages are queued and scheduled non-preemptively in priority-order. It is desirable to introduce more parallelism and concurrency into the system to improve predictability by adopting multi-threaded execution architecture. It is important to distinguish between the concepts of design-level concurrency and implementation-level concurrency [Saksena et. al 2000].

3. CONCEPTUAL MECHANISM OF STPM

As we aforementioned, this paper focuses towards the logical model development of the application which belongs to category I, of STPM's usage. So this section starts with the brief introduction of application oriented STPM architecture and ends by discussing the mechanism of the model which is highly correlated with the objective of the paper.

STPM consists with three process domain called temporal, spatio-temporal and spatial, two channels called TC, SC and STL_1 as a link. All the domains stand for their own process behaviors such as status of the process, signal generation and process progression etc. Each and every process has its unique way of processing representation. Domains play a vital role in STPM. Role of channels is the key factor in this model since they are the signal carriers between domains. Though channels don't have their own mechanism, they are useful to handshake [Worboys 2005] with entities of processes. STL_1 , spatio-temporal link represents the 1:1 relationship between temporal and spatial domains. Meanwhile it makes its contribution to arrange the sequence among processes.

3.1 Graphical Illustration of STPM's Mechanism

Applications belong to category I; have declared as location changes of evenly changeable spatio-temporal phenomena. Though such kind of phenomena would be hypothetical, motion of an object in vacuumed tube is a suitable example for it. The significance in such kind of motion is that, the object can maintain same velocity during its entire motion since no action could take place against the motion. Mechanism of this model totally based on the syntax and semantics of π -calculus. Temporal domain and spatial domain pass their particular time instances and locations through TC and SC channels to the spatio-temporal domain respectively. Status of the motion can be distinguished with those signals. Figure 1 shows the graphical representation of STPM for the application belongs to category I.

3.2 Literarily Illustration of STPM's Mechanism

The entire mechanism of STPM expresses as follows and the equation order presents the sequence of model mechanism. The equations, which have odd numbers prefixed with "M", represent the signal transmission between each domain. Rests represent the concurrent process progression.

$$Cl_1 \mid \left\{ \frac{t_1}{t} \right\} . \left\{ \frac{l_1}{l} \right\} . ST \mid Loc_1 \quad (M1)$$

$$Cl_1 \mid ST \rightarrow Cl_2 \mid ST \text{ And } Loc_1 \mid ST \rightarrow Loc_2 \mid ST \quad (M2)$$

$$Cl_2 \mid \left\{ \frac{t_2}{t_1} \right\} \cdot \left\{ \frac{l_2}{l_1} \right\} \cdot ST \mid Loc_2 \quad (M3)$$

$$Cl_2 \mid ST \rightarrow Cl_3 \mid ST \text{ And } Loc_2 \mid ST \rightarrow Loc_3 \mid ST \quad (M4)$$

$$Cl_3 \mid \left\{ \frac{t_3}{t_2} \right\} \cdot \left\{ \frac{l_3}{l_2} \right\} \cdot ST \mid Loc_3 \quad (M5)$$

$$Cl_3 \mid ST \rightarrow Cl_4 \mid ST \text{ And } Loc_3 \mid ST \rightarrow Loc_1 \mid ST \quad (M6)$$

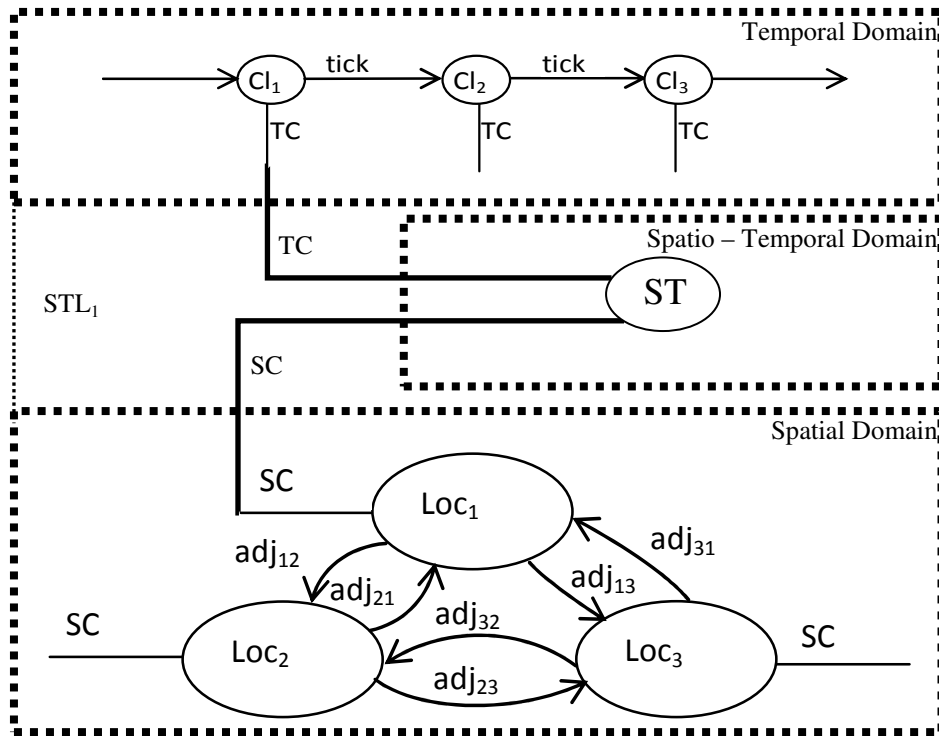

Figure 1 Conceptual Model of STPM

As further explication for equation M1, it stands for the signaled affiliation of the spatio-temporal process at time t_1 and location l_1 . Meanwhile the denominators represent the original or previous temporal and spatial signalize affiliations in combined fractional signals in spatio-temporal process, the numerators always stands for the current signalize affiliations. Similar kind of posture is afforded by the equations M3 and M5. *RECT* rule in π -calculus has made a great contribution for thus signal transmission. By applying the *PAR* rule in π -calculus for the concurrent process progression, equations M2, M4 and M6 can be derived. In equation M2, when Cl_1 and ST happen, process advancement reaction also occurs in this composition by changing process Cl_1 to Cl_2 . It expresses that, while the reaction takes place between entity and time, time can advance individually. Similarly, location also can be changed while the reaction happens between entity and location. It is possible to make the similar interpretation for equation M4 and M6.

4. LOGICAL LEVEL ARCHITECTURE OF STPM

In this section, we present the logical level architecture of the aforesaid STPM based upon the UML-RT modeling principles and techniques. All the codes which belong to actions, methods and signals are written as statements in detail-level programming language (that is, in C++) in state machine and sequence diagram.

4.1 Structural Architecture

4.1.1 Static Structure

Each domain has unique responsibilities over its process. So, there is no any contradiction for the declaration of each domain as single modeling component. When considering STPM's mechanism in broad sense, it is not complicated to understand the complete Spatio-Temporal phenomenon as a modeling component. As a fundamental modeling component in UML-RT, capsules assign for all three domains and Spatio-Temporal phenomenon. Meanwhile STL₁ link represent as an association relationship, since both temporal and spatial domains have independent identities. Figure 2 illustrates the static structure of STPM and Table 1 implies the properties of mapping components, capsules.

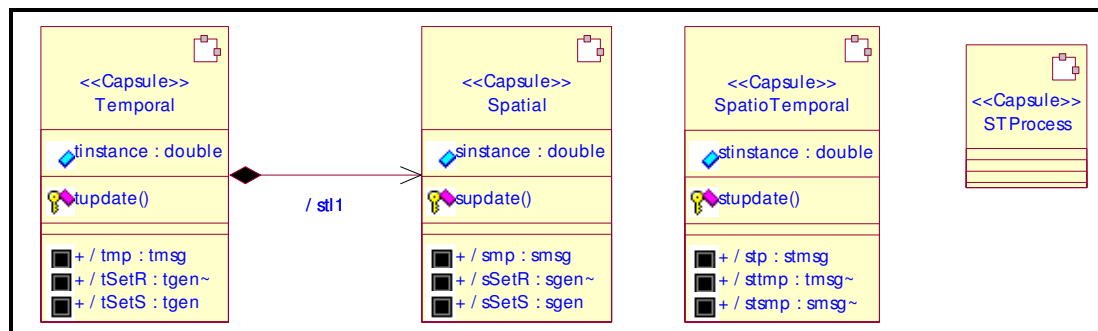

Figure 2 Class Diagram of STPM

Table 1 Properties of Capsules

Capsule	Role	Attributes	Methods	Ports	Connector
Temporal	Temporal domain	tinstance	tupdate()	tmp tSet	-
Spatial	Spatial Domain	sintance	supdate()	smp sSet	-
SpatioTemporal	Spatio-Temporal Domain	stinstance	-	stp sttmp sttmp	-
STProcess	Spatio -Temporal phenomenon	-	-		TC SC

4.1.2 Communication Pattern

Henceforth, the model architecture of STPM have discussed within the milieu of *STProcess* capsule. The set of messages exchange between two objects conforms to some communication pattern called protocol. We use three protocols for structural modeling and two ports for behavioral modeling. These three protocols are conformed the signal transmission in between capsules. Connectors (Channel) *TC* and *SC*, occupy the roles of protocol *tmsg* and *smsg* respectively. Role of protocols *stmsg* is occupied by itself from the capsule *SpatioTemporal*. The structure diagram of STPM Figure 3 and Table 2 illustrate the communication pattern which is owned by particular capsules (precisely instances of respective capsules) and the communication between capsules.

Table 2 Communication Pattern

Protocol	Port	Capsule	In Signal	Out Signal
tmsg	tmp	Temporal		tmsgsignal
	sttmp	SpatioTemporal	Tmsgsignal	
smsg	smp	Spatial		smsgsignal
	sttmp	SpatioTemporal	Smsgsignal	
stmsg	stp	SpatioTemporal	Stsignal	stsignal

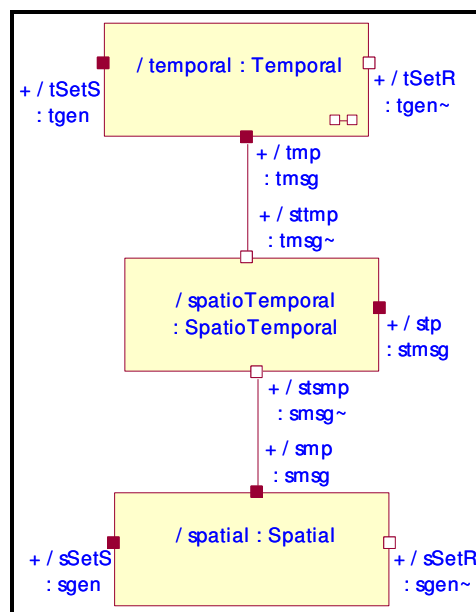

Figure 3 Structure Diagram of STPM

4.1.3 Communication Scenario

Communication scenario has explained by the sequence diagram (Figure 4), in UML-RT as follows. *Temporal* and *Spatial* objects send their out signals (that is, mentioned in Table 2) to the *SpatioTemporal* object at the same time. *SpatioTemporal* object generates its out signal

and send them back to itself for its status update just after receiving signals. This signal transmission process repeats until another two (2) consecutive stages. *SpatioTemporal* object emits a destructive signal to itself for terminates its process, just after updating its third status. This happens due to our termination the mechanism of STPM up to three process instances for an illustration convenience. The entire sequence diagram consists with asynchronize message, since neither *SpatioTemporal* object makes reply to *Temporal* nor *Spatial* objects. We have drawn the entire repeated step in sequence diagram without using a loop, because of the less support of UML – RT for loop condition modeling.

Rose RT codes for π -Calculus based signal transmission mechanism has specific manner in C++ environments. Message receiving term has already internally configured as trigger information and “port a and signal λ ”, emphasis that the port a receive signal λ . The message sending term “ a send $\lambda (p)$ ” codes as “ $a.\lambda(pAtt).send();$ ”, where port a sends the signal λ with the message $pAtt$. Tabular illustration for communication scenario mentioned in Table 3, as follows. It is important to note that, we have declared messages in Table 3, as their general form such as “ $tnAtt, lnAtt$ and $stnAtt$ ”, where n is an integer varies from 1 to 3 due to behavioral changes of Capsule *Temporal* and *Spatial*.

4.2 Behavioral Architecture

The capsule *STProcess* comprises the following capsules: *temporal* (instance of the Capsule *Temporal*), *spatioTemporal* (instance of the Capsule *SpatioTemporal*) and *spatial* (instance of the Capsule *Spatial*). Table 4, illustrates the entry and exit actions of the states in the sub capsules in *STProcess* Capsule. The message p implies as “ $pAtt = *rtdata;$ ”, where $pAtt$ is an attribute and the received or retrieve message is in the form of $*rtdata$. We provide the state diagram of the Capsules *Temporal*, *Spatial* and *SpatioTemporal* respectively, in Figures 5, 6 and 7.

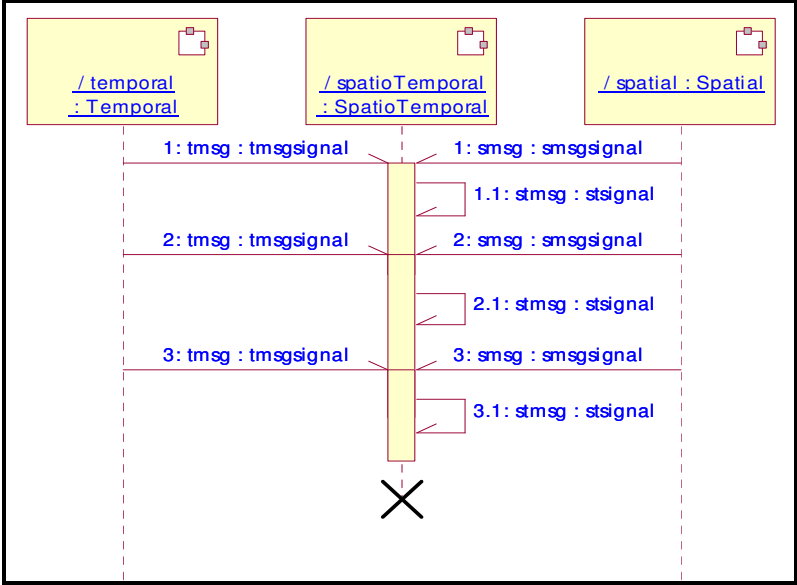

Figure 4 Communication Sequence

Table 3 Signal Structure

Protocol	Trigger		Action
	Port	Signal	
tmsg	sttmp	tmsgsignal	tmp.tmsgsignal(t_n Att).send();
smsg	stsmg	smsgsignal	smp.smsgsignal(l_n Att).send();
stmsg	stp	stsignal	stp.stsignal(st_n Att).send();

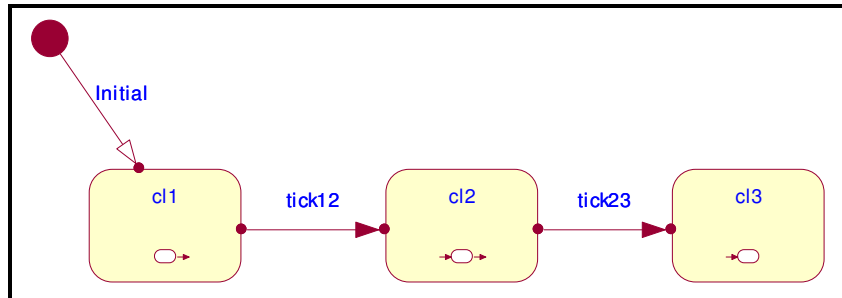

Figure 5 State Diagram of Temporal Domain

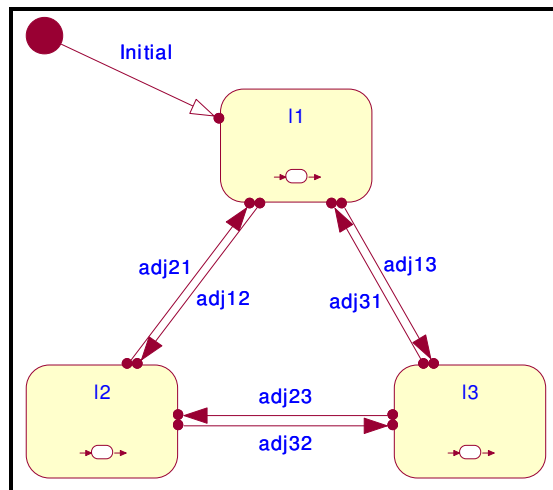

Figure 6 State Diagram of Spatial Domain

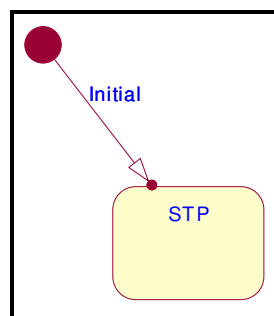

Figure 7 State Diagram of Spatio – Temporal Domain

Table 4 Entry and Exit actions of STPM Capsules

Capsule	State	Entry Action	Exit Action
Temporal	C11	–	t ₂ Att = *rtdata;
	C12	tupdate(tchange(t ₂ Att));	t ₃ Att = *rtdata;
	C13	tupdate(tchange(t ₃ Att));	–
Spatial	L1	supdate(schange(l ₁ Att));	L ₂ Att = *rtdata; L ₃ Att = *rtdata;
	L2	supdate(schange(l ₂ Att));	L ₁ Att = *rtdata; L ₃ Att = *rtdata
	L3	supdate(schange(l ₃ Att));	L ₂ Att = *rtdata; L ₁ Att = *rtdata;
SpatioTemporal	STP	t _n Att = *rtdata; l _n Att = *rtdata st _n Att = (t _n Att, l _n Att) stupdate(st _n Att)	–

Table 5 Transition Table in STPM

Capsule	Transition	Trigger		Action
		Port	Signal	
Temporal	initial	–	–	–
	tick12	tSetR	tchange	tSetS.tchange(t ₂ Att).send();
	tick23	tSetR	tchange	tSetS.tchange(t ₃ Att).send();
Spatial	initial	–	–	–
	adj12	sSetR	schange	sSetS.schange(l ₂ Att).send();
	adj21	sSetR	schange	sSetS.schange(l ₁ Att).send();
	adj23	sSetR	schange	sSetS.schange(l ₃ Att).send();
	adj32	sSetR	schange	sSetS.schange(l ₂ Att).send();
	adj31	sSetR	schange	sSetS.schange(l ₁ Att).send();
adj13	sSetR	schange	sSetS.schange(l ₃ Att).send();	
SpatioTemporal	initial	–	–	–

While, the entry action represents the action that take place whenever entering the state, the action that happens whenever leaving from the state signified by the exit action. Usually the initial state doesn't have much necessity of the entry action. But the dual transitions (forward and reverse) supercede this situation. Roles of Methods *tupdate()* and *supdate()* are to update the temporal status in Capsule *Temporal* and update spatial status in Capsule *Spatial* after receiving the message with the corresponding transitional signal respectively. Method *stupdate()* is responsible for updating the status in Capsule *SpatioTemporal*, after receiving aforementioned signals in Table 3. Typically exit action is followed by the transition. But it doesn't imply the necessity of exit action for transitions indeed.

Table 6 Pseudo Coded Transition Table in STPM

Capsule	Transition	Trigger pseudo code	Action pseudo code
Temporal	initial	–	–
	tick12	tSetR in c12 receive tchange(t ₂ Att)	tSetS in c11 send tchange(t ₂ Att)
	tick23	tSetR in c13 receive tchange(t ₃ Att)	tSetS in c12 send tchange(t ₃ Att)
Spatial	Initial	–	–
	adj12	sSetR in l2 receive schange(l ₂ Att)	sSetS in l1 send schange(l ₂ Att)
	adj21	sSetR in l1 receive schange(l ₁ Att)	sSetS in l2 send schange(l ₁ Att)
	adj23	sSetR in l3 receive schange(l ₃ Att)	sSetS in l2 send schange(l ₃ Att)
	adj32	sSetR in l2 receive schange(l ₂ Att)	sSetS in l3 send schange(l ₂ Att)
	adj31	sSetR in l1 receive schange(l ₁ Att)	sSetS in l3 send schange(l ₁ Att)
SpatioTemporal	adj13	sSetR in l3 receive schange(l ₃ Att)	sSetS in l1 send schange(l ₃ Att)
	initial	–	–

The specification of the transitions inside the state diagrams of the sub capsules *Temporal*, *Spatial* and *SpatioTemporal* of the Capsule *STProcess* is referred to Table 5. It is important to note that any action may not take place with the transition initial inside of the sub capsules *Temporal*, *Spatial* and *SpatioTemporal*. Sub capsule *SpatioTemporal* hasn't contained any transition except *initial* since it represents the unique process. The pseudo code translation of Table 5 is presented in Table 6; the pseudo code helps to understand the π -Calculus based mechanism in this STPM.

5. CONCLUSION

In this paper, we implemented our conceptual methodological approach of Spatio-Temporal Process Model (STPM), discussed in a previous paper [Xu et. al 2009] up to logical level, with the integration of UML-RT modeling language in order to capture the π -Calculus based internal mechanism and process oriented structure of system components. This new contribution strengthens our conceptual model; since we can systematical obtain a detailed system specification from an initial theoretical model.

As we aforementioned, our suggestion was the modeling software and all the applicable techniques which we used for this work should have public standards. So we had to aware of many other related works within the milieu of UML-RT modeling and it's applicability to π -Calculus. The critical factor of all the substantial papers was the model verification capability of UML-RT. There is a contradiction between papers, regarding that convenience in UML-

RT. But we have decided UML-RT has that capability; since after referring the manual and tutorials of the latest version in UML-RT (Version 6.5).

As our suggestions this model is ideal for *synchronous* domains, which are all temporally referenced entities handshake with processes in the same clock, and *syntopic* domains, which can share the same habits within the same geographic range. But our aspiration is to make further development of this model, which appropriates to *asynchronous* and *asyntopic* domains also.

We believe STPM shall make a new propensity in dynamic modeling regarding the spatio-temporal phenomena; since it represents the reality in the world. But, for making a good consciousness of this STPM, it requires more of a conceptual leap regarding the process views, especially the space.

ACKNOWLEDGMENT

The research is supported by Projects of Liaoning Province University Innovation Team (2008T085) and Liaoning Province University Key Laboratory (2009S049)

REFERENCES

- Gherbi A and Khendek F (2006) UML Profiles for Real-Time Systems and their Applications. *Journal of Object Technology* Vol 5(4): 149-169.
- Langran G and Chrisman N R (1988) A framework for temporal geographic information. *Cartographica: The International Journal for Geographic Information and Geovisualization* Vol 25(3):1 – 14.
- Milner R (1999) *Communicating and Mobile Systems: The π -calculus*, Cambridge.
- Peuquet D J and Duan N (1995) An event-based spatiotemporal data model (ESTDM) for temporal analysis of geographical data. *International Journal of Geographical Information Systems* 9(1): 7-24.
- Saksena M and Karvelas P (2000) Designing for schedulability: integrating schedulability analysis with object-oriented design, in *Proc. IEEE Euro-Micro Conference on Real-Time Systems*, 101–108.
- Selic B, Gullekson G, and Ward P T (1994) *Real-Time Object-Oriented Modeling*. John Wiley and Sons,
- Worboys M F (2005) Event-oriented approaches to geographic phenomena. *International Journal of Geographic Information Systems* Vol. 19(1): 1 – 28.
- Xu A and Lakmal A H (2009) Signal Transmission to Concurrent Processes: Spatio-Temporal Process Model, in *Proc. IEEE 2nd International Congress on Image and Signal Processing*, Vol. 1: 356 – 360.

Yuan M (1996) Temporal GIS and Spatio-Temporal Modeling. In: Third International Conference/Workshop on Integrating GIS and Environmental Modeling. NCGIA. http://ncgia.ucsb.edu/conf/SANTA_FE_CD-ROM/sf_papers/yuan_may/may.html,

BIOGRAPHICAL NOTES

Prof. Aigong XU received his Ph.D in Wuhan Technical University of Surveying and Mapping (now Wuhan University) in 1998. He worked as a postdoctor in Tongji University from 1999 to 2000, as a research fellow in Nanyang Technological University, Singapore from 2001 to 2003, and as a visiting scholar in the Chinese University of Hong Kong in 2005. Currently, he works as a professor in the School of Geomatics, Liaoning Technical University, China. Prof. Aigong Xu is vice director of Geodesy Professional Committee and member of Surveying Educational Committee in Chinese Society for Geodesy, Photogrammetry and Cartography.

Mr. Askey Harinda LAKMAL is from Sri Lanka. He is a surveyor in his government. Mr. Lakmal completed his BSc (Surveying Sciences) in 2002. Then he received his MSc (GIS & Remote Sensing) in University of Peradeniya, Sri Lanka in 2008. He won the PGIS Merit Scholarship for his best performance in MSc from the University of Peradeniya. Mr. Lakmal is a member of Surveyors' Institute of Sri Lanka (SISL) and Geoinformatics Society of Sri Lanka (GISSL). At present, he is a Ph.D candidate in the School of Geomatics, Liaoning Technical University supported by Scholarship of Liaoning Province, China.

CONTACTS

Professor Aigong XU
School of Geomatics, Liaoning Technical University
47 Zhonghua Road
Fuxin, Liaoning Province
CHINA 123000
Tel. +86 418 3350145
Fax + 86 418 3350145
Email: xu_ag@126.com
Web site: www.lntu.edu.cn