

Engineering Survey System for TBM (Tunnel Boring Machine) Tunnel Construction

Andrew Hung Shing Lee, Hong Kong

Key words: TBM, Tunnel Guidance System, Zigzag Traverse.

SUMMARY

For a TBM tunnel project, it is essential to establish a flawless engineering survey system to ensure that the tunnel being excavated and built is in accordance with the predefined alignment. Most importantly, the ultimate goal is to construct the tunnel such that it does not exceed the allowable construction tolerance.

A tunnel guidance system is tailored made for the TBM to continuously track the position and direction of the machine in course of excavating. The geo-spatial data of the machine is instantaneously displayed on the screen at the TBM control cabin. The pilot would make use of the information to steer the machine to match the design alignment.

In this article the author explored and evaluated the Engineering Survey System adopted for the 3.2Km TBM Tunnel of Lok Ma Chau Spur Line, a 7.5Km railway project constructed for Kowloon Canton Railway Corporation in Hong Kong, SAR from 2002 to 2006.

1 INTRODUCTION

Tunnel construction by means of TBM (Tunnel Boring Machine) has become a preferred method of construction nowadays. In addition, this is well accepted by the environmentalist and the green groups. This state-of-art technology limits all works underground in building the tunnel to keep the disturbance to land, wildlife and mankind activities at ground level to a minimum throughout the period of construction.

Tunnel construction by TBM is quite different from the traditional Drill and Blast Method. The tunnel is excavated by means of a machine instead of blasting with explosive. The tunnel lining is put in place at the back of the machine immediately following a ring length of TBM advancement. A well thought engineering survey scheme is devised to integrate with the operating system and working sequence of the TBM.

For the TBM tunnel of the Lok Ma Chau Spur Line, firstly the TBM took a break in from the launching shaft at Sheung Shui and travelled 1.7Km to reach Kwu Tung East. The TBM moved ahead 300m by jacking and took a second break in from Kwu Tung West and travelled another 1.4 Km to reach the extraction shaft at Chau Tau to complete the down track tunnel.

The TBM was then overhauled, retrieved and brought back to the launching shaft where it was reassembled for the drive of up track tunnel running in parallel some 14m away from the constructed down track tunnel. The TBM took a similar third break in at Sheung Shui, a fourth break in at Kwu Tung and again advanced to extraction shaft at Chau Tau to complete the task.

2. BUILDING OF TUNNEL

2.1 Major Component of TBM

	Component	Function
1	Cutter Disc	To excavate rock or soft ground by the rotation of an assembly of teeth or cutting wheels under pressure against rock face.
2	Shield Skin	To keep the soil from getting into the machine and to provide a safe space for the workers.
3	Pushing Jack	To be in full contact with the erected segment and extend by hydraulic as the cutter disc turns and thrusts forward.
4	Main Drive	To provide a force in rotating the cutter disc and is powered by electricity.
5	Screw Conveyor	To move the spoil at the cutter disc and feed onto a conveyor system.
6	Erector	To erect the segments to form a complete ring after shoving at the tail of the TBM.
7	Back Up Facilities	To travel with the TBM and to service the operation of annular grouting, welding, extension of ventilation, power and track etc.

Table 1

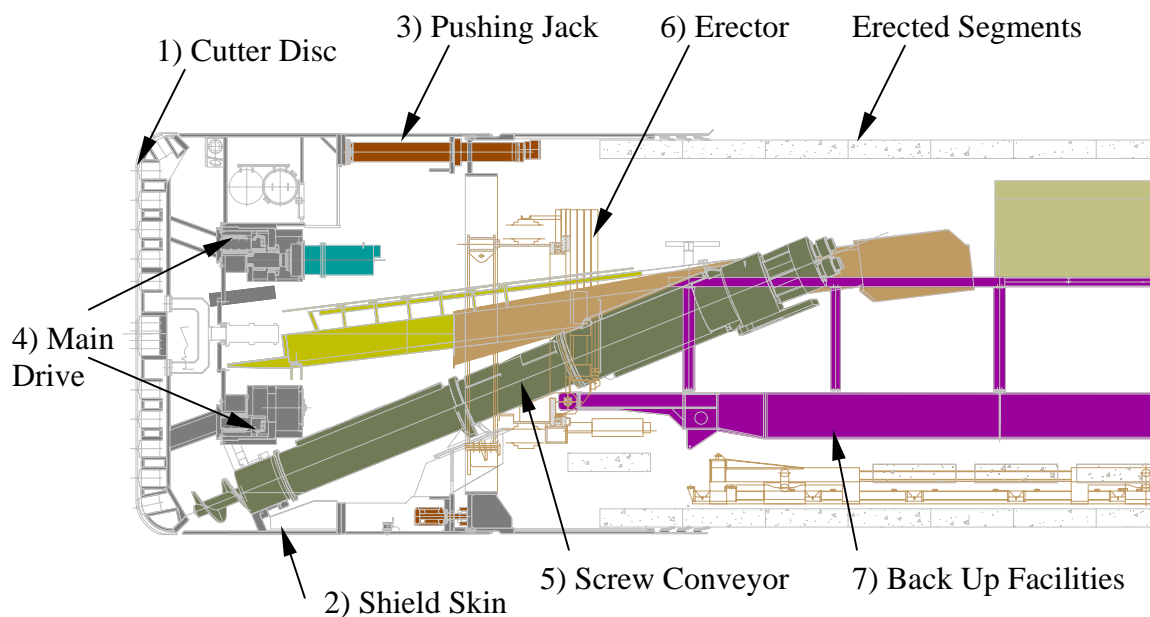

Figure 1 Typical Layout of a TBM

2.2 Operating Sequence of a TBM

The TBM moved forward as it excavated the tunnel by extending the pushing jacks at the back. When the advancement of the machine reached distance of the length of a ring, the excavation stopped and the pushing jacks were retrieved, a concert circular ring in form of a numbers of segments were then put together at the tail of the shield. The pushing arms were once again extended in full contact with the concert ring just erected and excavation resumed. The cycle of excavation and ring erection repeated as the TBM advanced to form the lining of the tunnel (Figure 2).



Figure 2 The lining of the tunnel is formed by a continuation built up of the rings

3. SURVEY METHODOLOGY

3.1 Pre-construction Stage

3.1.1 (Step 1 of 4)

Identified the geographical extent of the construction works involved and designed a scheme of survey control network to cover the area .

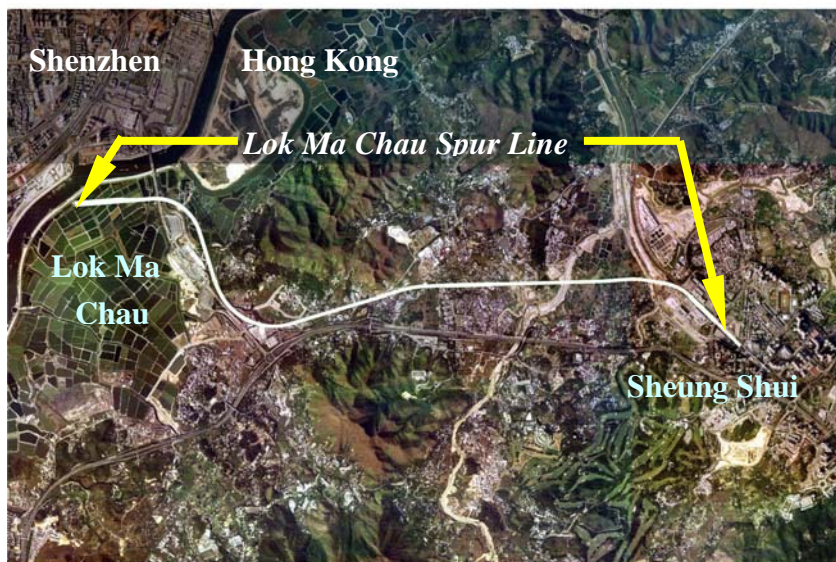
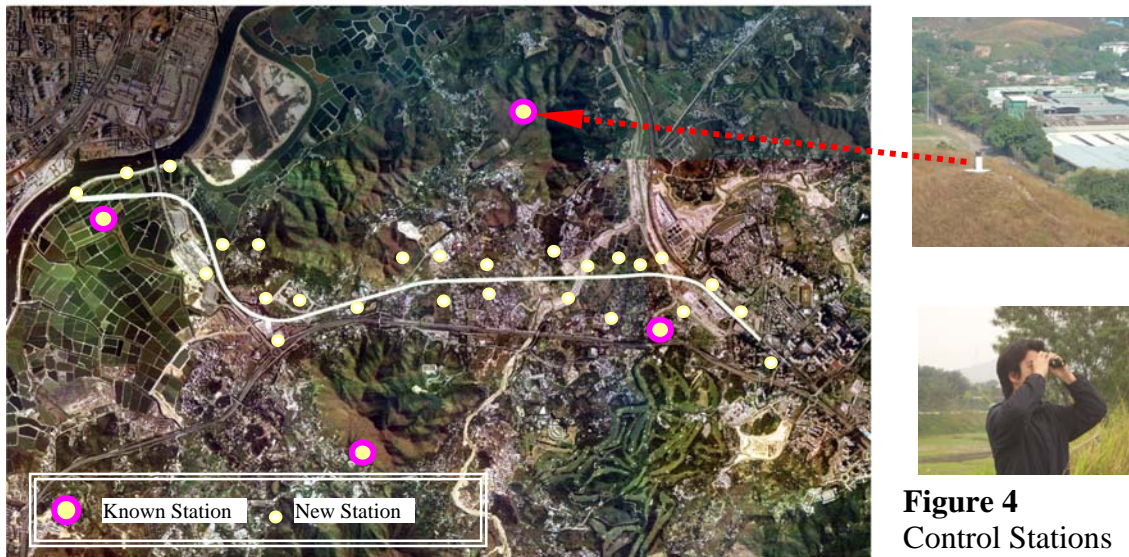

Figure 3
The Lok Ma
Chau Spur Line

3.1.2 (Step 2 of 4)

Carried out a reconnaissance survey on site to identify the known control stations nearby and established the new survey stations (Figure 4).



3.1.3 (Step 3 of 4)

Set up a survey control network, the new stations were rigidly tied to the known stations (Figure 5).

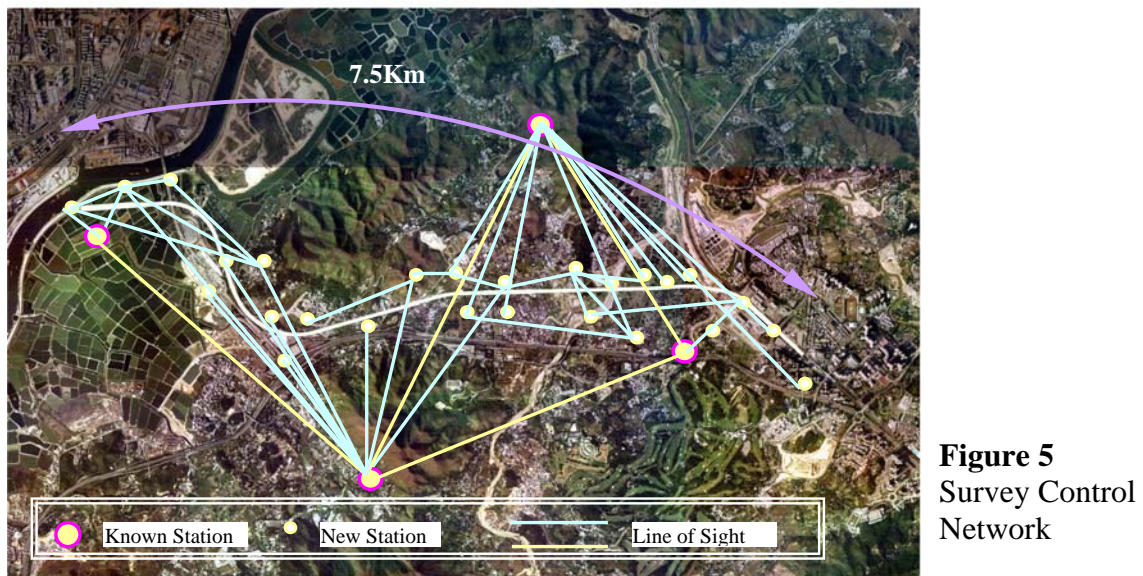

3.1.4 (Step 4 of 4)

Carried out field measurements of angle and distance among the stations followed by computation of global coordinates of control stations.

All field measurements were to meet the following acceptance criterias before computation was performed.



Figure 6 Survey field work and computation at office

- 1) The spread of a repeated angle measurement should not be more than 3”.
 - 2) The spread of a repeated distance measurement should not be more than the measuring accuracy of total station (2mm+2ppm), 5mm for the 2.5km as an example.
- The global coordinates of the stations was finalized and would be made use of for construction as primary control stations. The accuracy of the stations is better than 1:50,000

3.2 Construction Stage

3.2.1 (Step 1 of 5)

Prior to the initial drive of TBM, secondary control station was established at the TBM Launching Shaft at surface by transferring co-ordinates from the primary control stations.

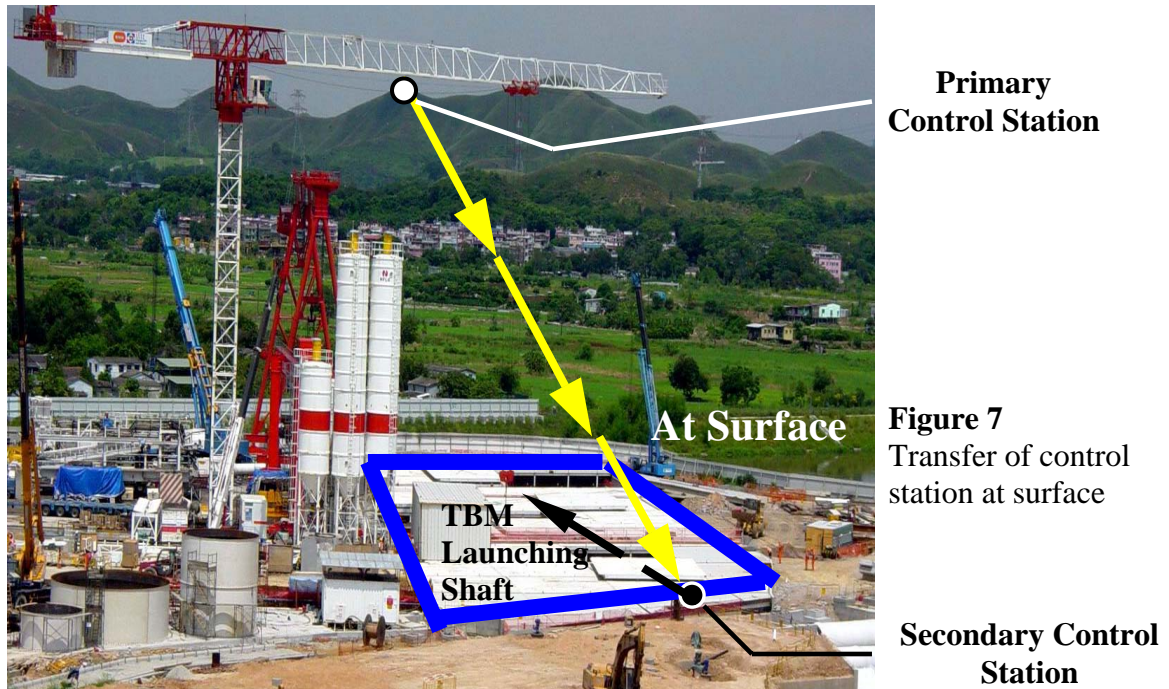

Primary Control Station

Figure 7
Transfer of control station at surface

Secondary Control Station

3.2.2 (Step 2 of 5)

Transferred the secondary control station from surface at the TBM Launching Shaft to the tunnel control station at underground level (Figure 8).

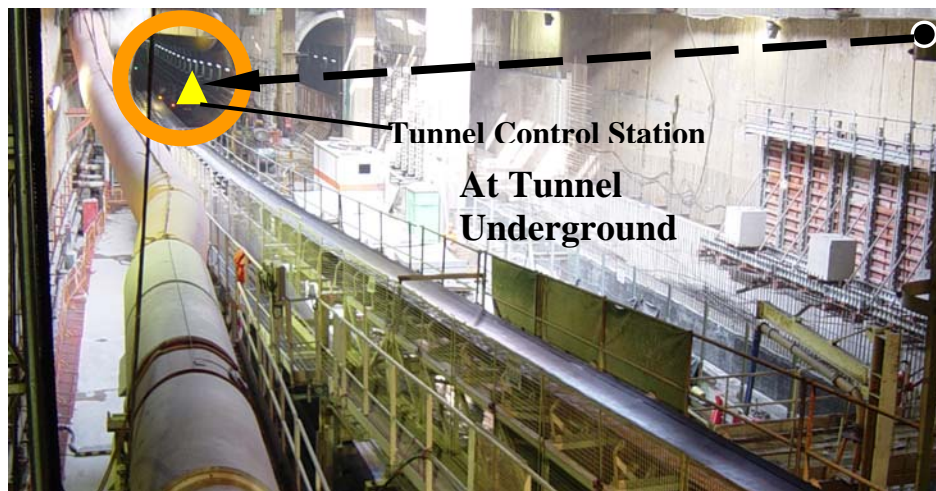

Secondary Control Station

Figure 8
Transfer of control station from surface to underground

3.2.3 (Step 3 of 5)

Moved up the tunnel control station by Double Zigzag Traverse(3.5) behind the TBM as the machine travelled ahead, and transferred a temporary station to the shoulder position of the erected ring at the back-up gantry of the TBM (Figure 9).

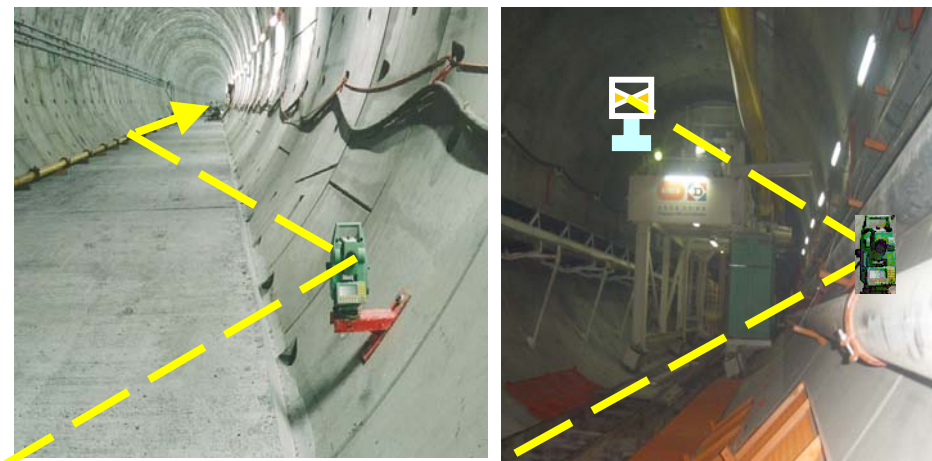

Figure 9
Zigzag traversing at the tunnel

Inside the Tunnel

3.2.4 (Step 4 of 5)

Traversed the temporary control stations at the erected rings above the TBM back up gantry to reach the Laser Station located about 30m behind the TBM.

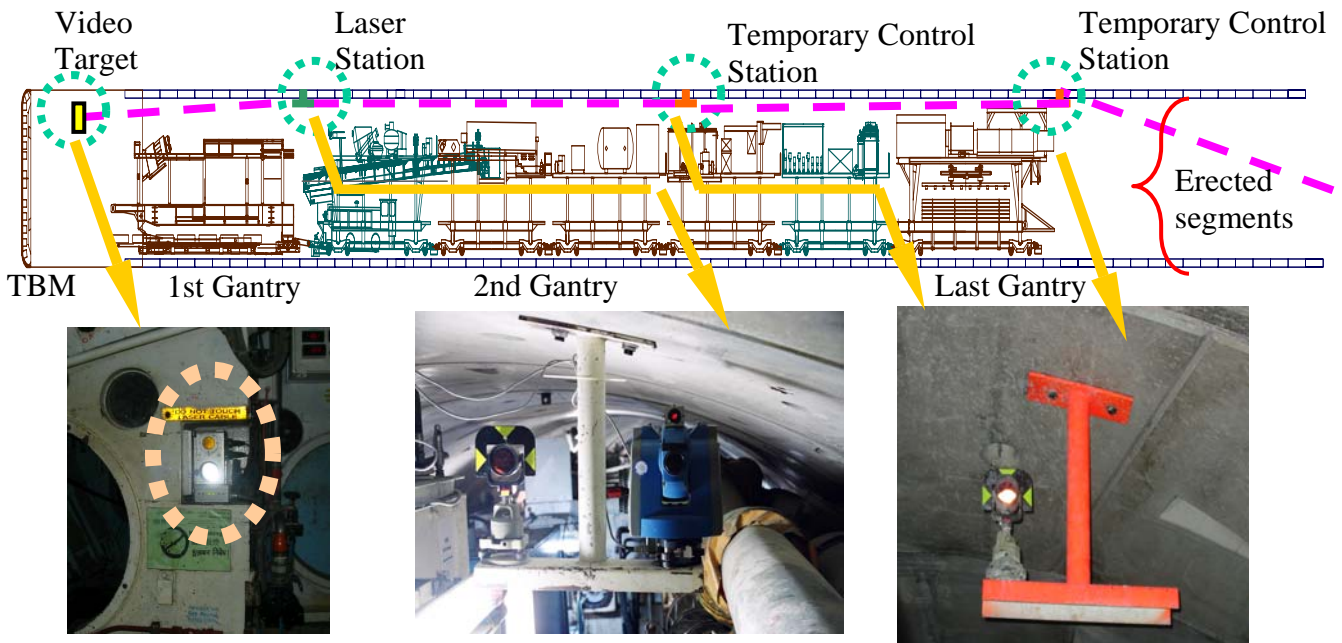

Figure 10 Transfer of control station at the TBM back up gantry

3.2.5 (Step 5 of 5)

The Laser Station carried the coordinates from the control station shot the prism target affixed to the bulkhead of TBM to determine the absolute spatial coordinates (x,y,z) of the TBM at that point. The tunnel guidance system and the dual axial inclinometers simultaneously measured the amount of rotation along the three perpendicular axis of the TBM to determine the orientation of the heading of the machine.

3.3 Working Principal of the TBM Guidance System

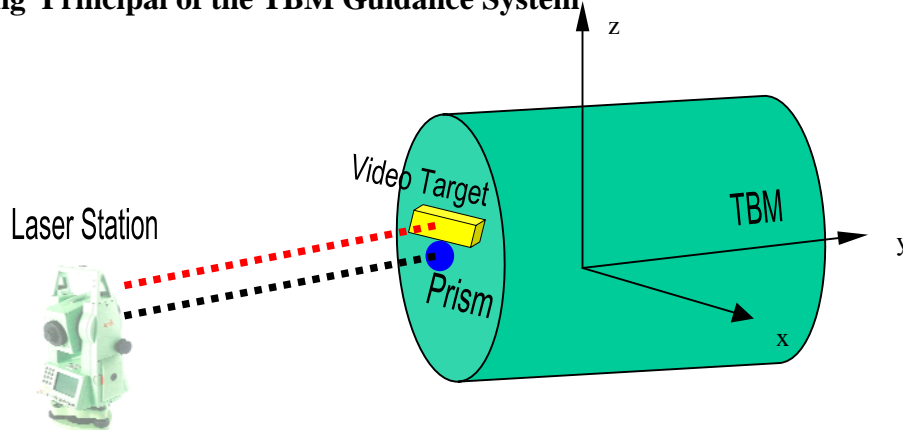

Figure 11 The Laser Station of the TBM Guidance System

3.3.1

In the XY Plane:

The Laser Station shined onto the Video Target. By analysing the laser image, the Video Target was able to measure the angle of incidence of the ray with the plane of the Video Target to determine the twist of the TBM.

By adding the twist to the true bearing carried forward from the Laser Station, The true bearing of the heading of the TBM was determined.

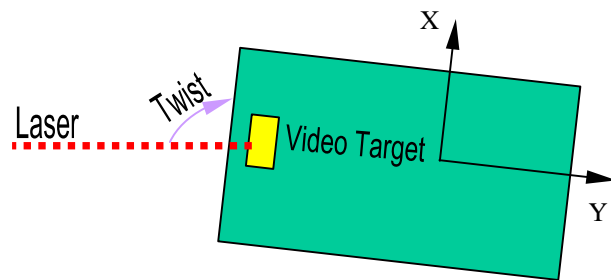

Figure 12 Plan View

3.3.2

In the XZ Plane:

A built in inclinometer 1 was placed in alignment with X-axis. The inclinometer measured electronically the roll of the TBM with respect to the plumb line.

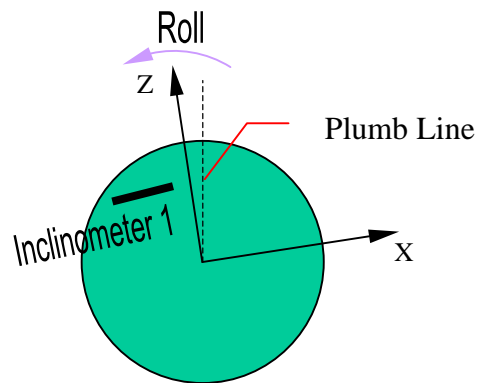

Figure 13 Section View

3.3.3

In the YZ Plane:

Another built in inclinometer 2 was placed in alignment with Y-axis. The inclinometer measured electronically the tilt of the TBM with respect to the level line.

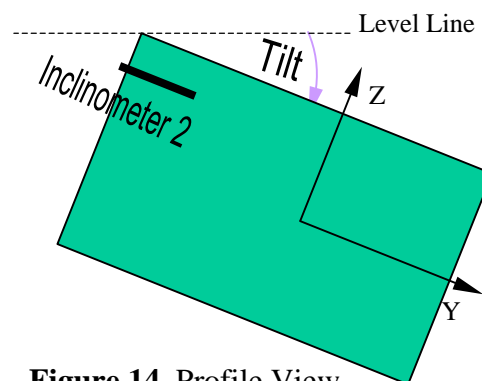

Figure 14 Profile View

3.3.4

The Laser Station determined the 3D position of the TBM, the Video Target determined the twist in XY plane, the Inclinator 1 determined the roll in XZ plane and the Inclinator 2 determined the tilt in YZ plane.

The Laser Station, the prism, video target and the dual axis inclinometers 1 and 2 are the instrumentation to capture the data to determine the spatial position and orientation of the TBM.

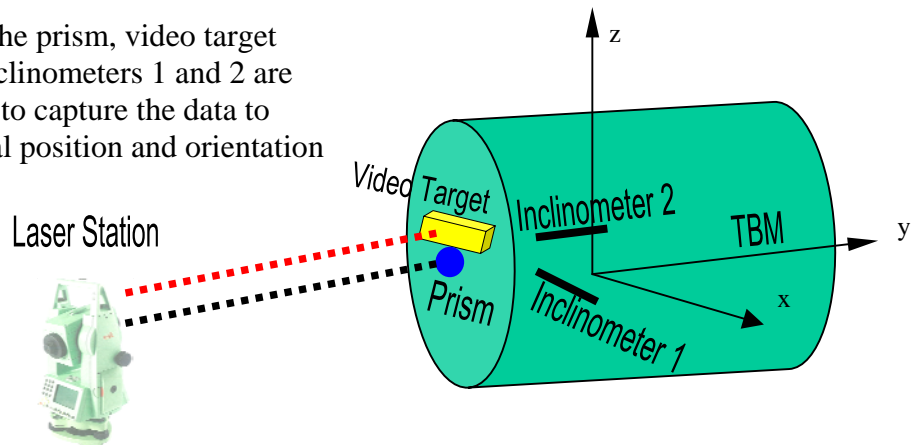

Figure 15 The mechanism of data acquisition of the tunnel guidance system

3.3.5

The laser station with the built in robotic mechanism tracked the prism continuously as the TBM advanced, updating the spatial position and the orientation of the TBM in every 10 seconds (Figure 16).

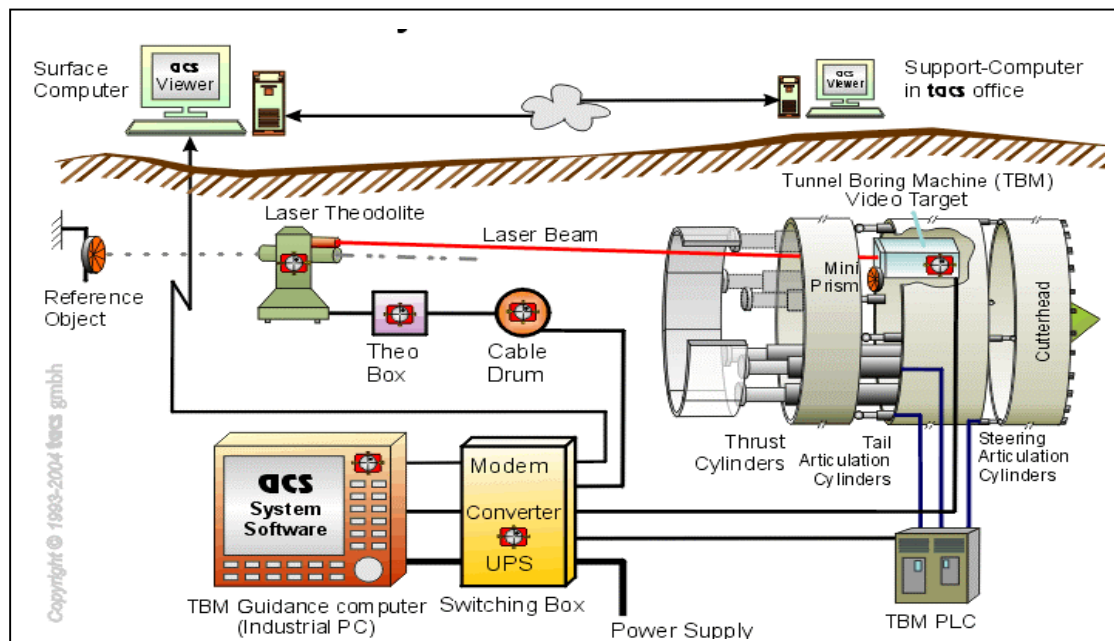

Figure 16 Processing of captured data of the moving TBM

The system linked to the TBM control cabin (Figure 17), where on the screen the positional deviation of the TBM with the Design Tunnel Axis was displayed (Figure 18) instantaneously in graphical and numerical formats at all times to aid the pilot to steer the machine.

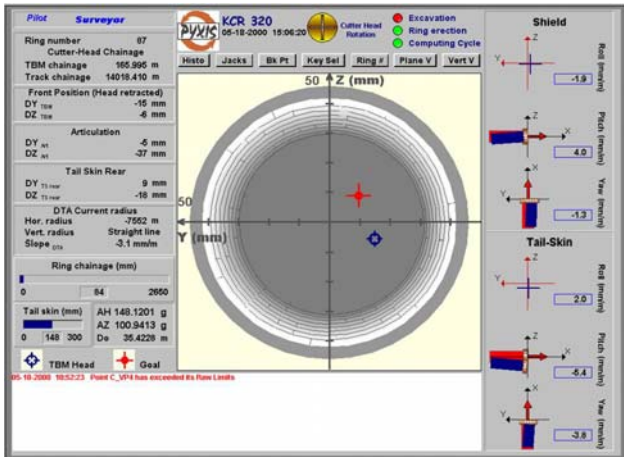

Figure 18 The screen display of the travelling TBM and its deviation from the design path.



Figure 17 Control cabin

The extension of the Articulation Jacks allowed the TBM to turn flexibly and advance forward in the direction of the design tunnel axis (Figure 19 and 20).

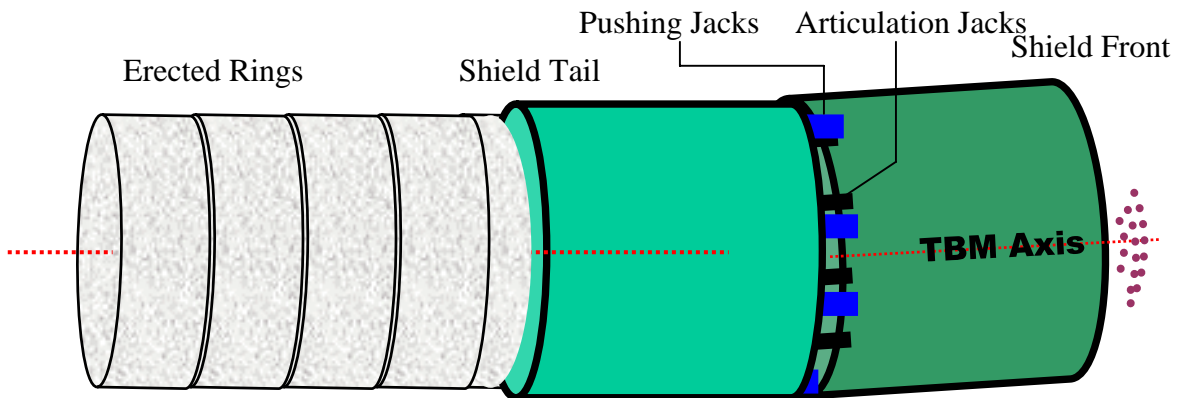

Figure 19

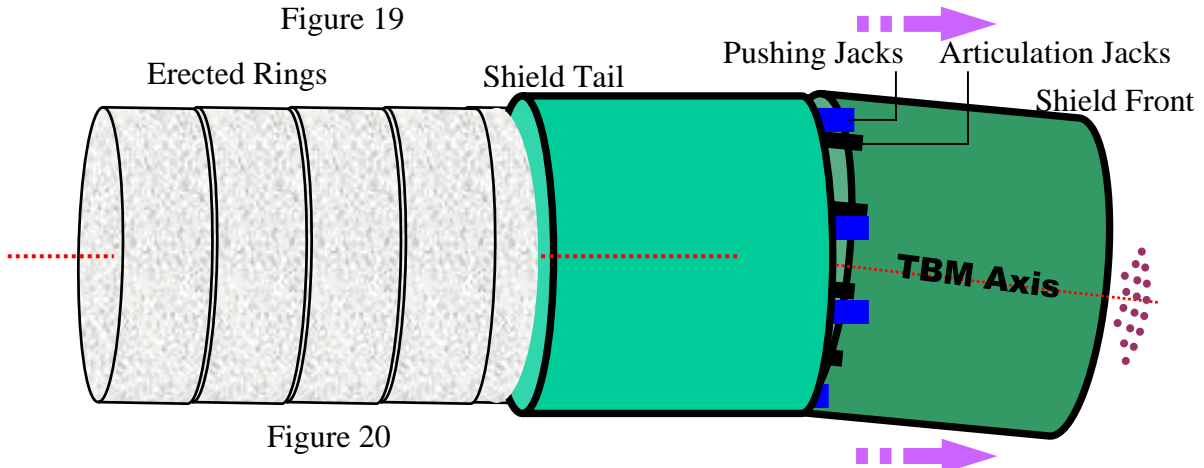

Figure 20

Tail Skin Clearance between the segment and the tail skin.
 The elongation of all pushing jacks and the shield tail clearance were measured by sensors and sent to the computer to derive the position of ring just erected (Figure 21)

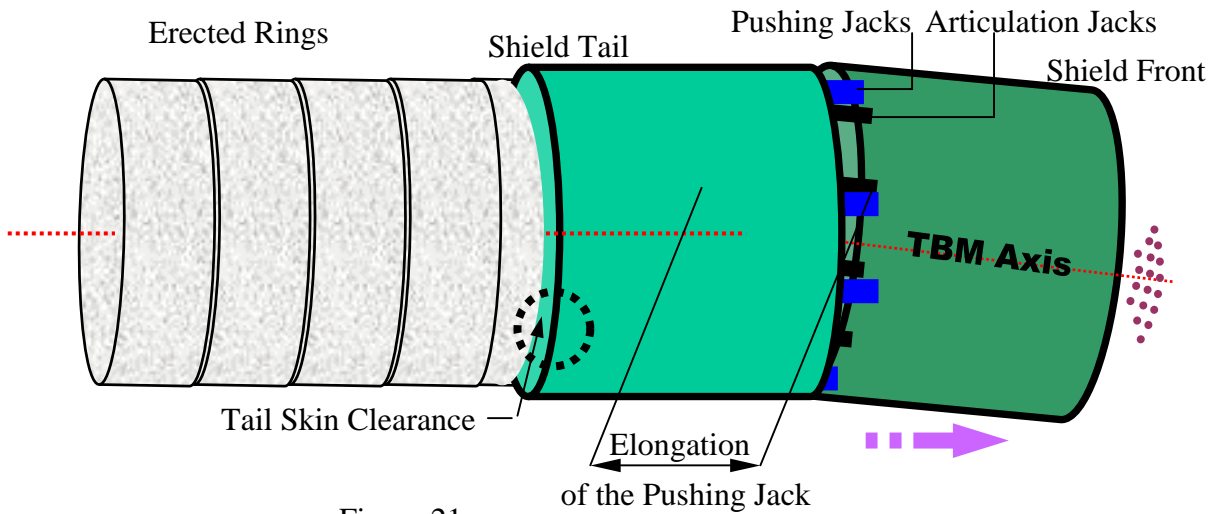

Figure 21

3.4 Post-construction Stage

3.4.1 (Step 1 of 2)

An eight points Wriggle Survey was carried out on the as built profile of the tunnel lining

- 1) For construction tolerance check
- 2) For dimension tolerance check of the diameter

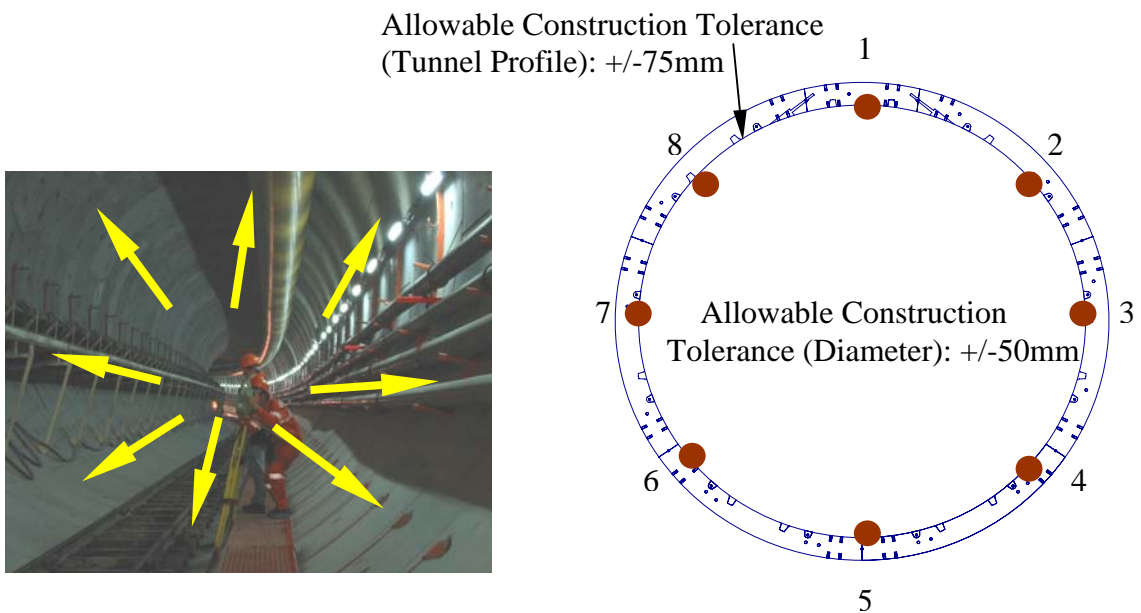

Figure 22 A standard eight point wriggle survey

The Structure Gauge (Figure 23) is the boundary related to the designated normal coordinated axis of the train, which enclosed the space for the safe operation of the train.

No fixed structures including the tunnel lining should infringe in the structure gauge.

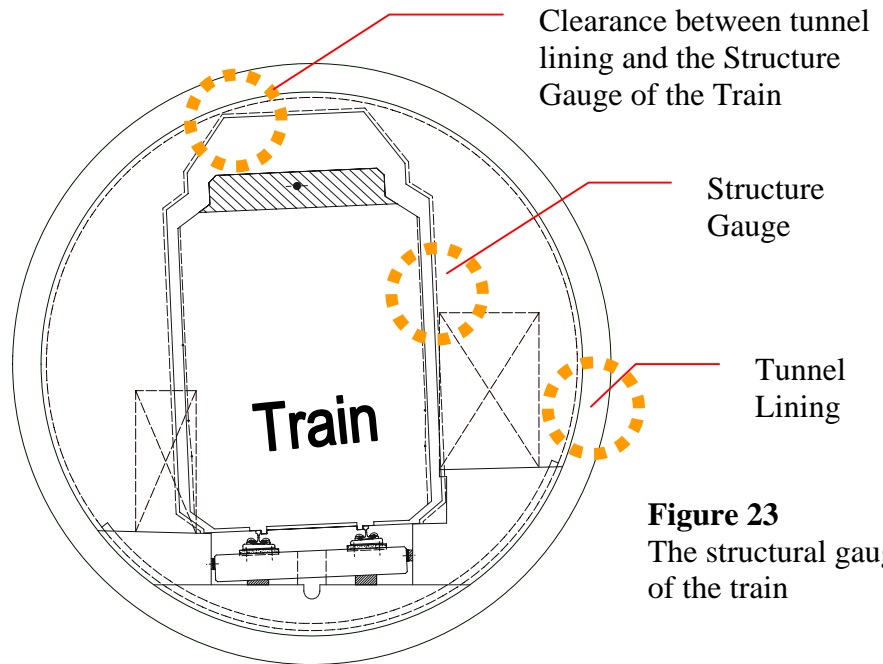

Figure 23
The structural gauge of the train

3.4.2 (Step 2 of 2)

Surveyor verified the wriggle survey data before it was passed to the Railway System Group for further assessment. Should the tunnel infringe the structure gauge occur (Figure 24), either the tunnel builder would propose a method for rectification or the tunnel builder would seek relaxation from the Railway System Group. If neither of the above works, the track would be realigned to fit the as-built profile of the tunnel as not to foul the structure gauge.

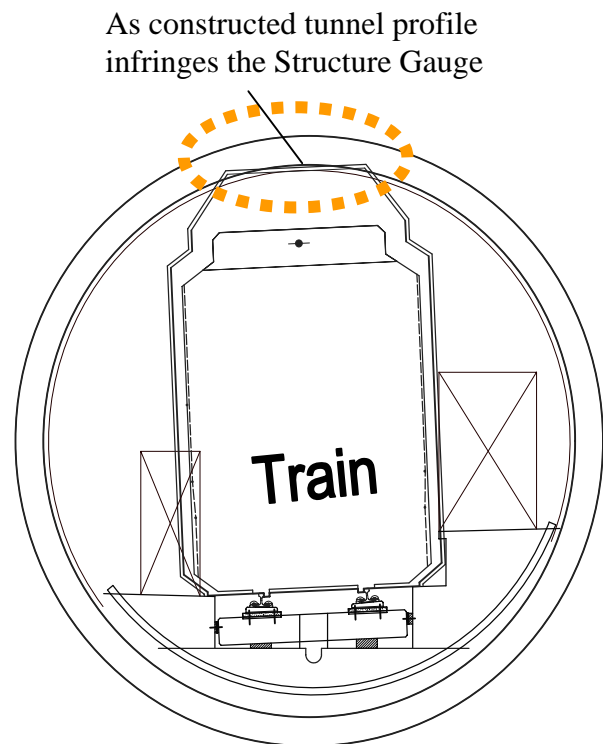

Figure 24
Infringement of the structural gauge of the train

3.5 Survey Control And Benchmark At The Tunnel

A “Double Zigzag Traverse” method was employed to advance the survey control station at the back of TBM to keep pace with the machine in moving forward.

The method consisted of beginning with setting a first set of stations in pair about 10m apart on one side of the tunnel and they were connected to the second set of stations in pair about 250m ahead on the other side of the tunnel. The second set of stations was then connected to the third set of survey stations in pair 250m in front on the opposite side of the tunnel. The fourth set and the rest of the control stations were set up in the similar zigzag manners to reach the break through end of the tunnel.

Angle observations from the pair station were taken to the two backsight and two foresight stations on the opposite side of the tunnel. Angle measurement to the same pairing station 10m away from the set up station was skipped owing to the unfavourable short sighting distance.

Distance measurement of all legs of the traverse was taken including the short distance to the pairing station. The first two consecutive pairs of stations formed a slim quadrilateral A1, A2, B2 and B1 (Figure 25). In essence, the geometry of the control stations was a chain of rigid quadrilateral stitching together.

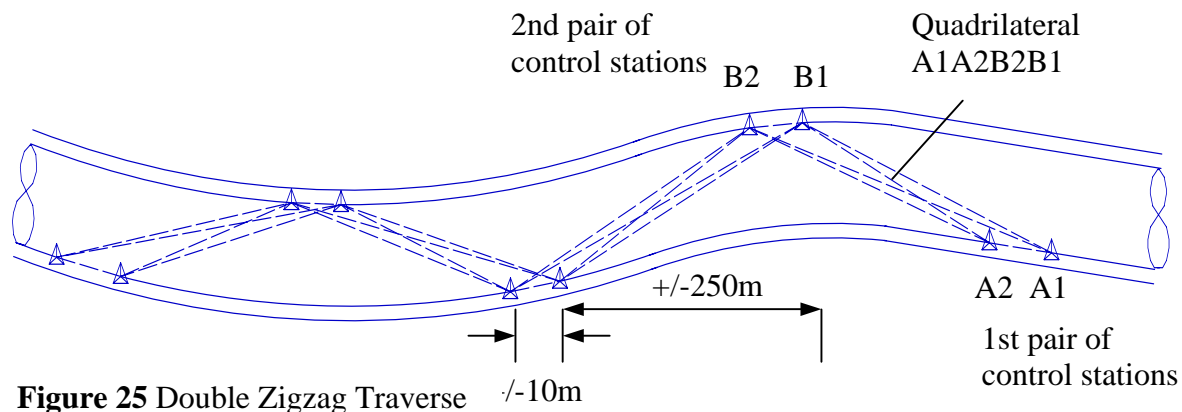

Figure 25 Double Zigzag Traverse

Prior to the breakthrough, computation of the stations coordinates was performed by Traverse Method on site and verified by Variation of Coordinate Method at the office for the detection of gross error. The surveyor at the TBM tunnel was capable to provide accurate survey information with confidence to keep the TBM operation uninterrupted at all times. After the tunnel break through, the last TBM control station was tied to the known station at the other end for closure check. The coordinates of all control stations were recomputed with the Method of Least Square of Adjustment.

For the benchmarks they were set at approximately every 180m above the higher walkway of the tunnel in an attempt to keep them intact throughout the project. The turning points between benchmarks were set about 40m apart and they were also put at strategic places for the ease of access and recovery (Figure 26).

The last benchmark was tied to the known benchmark to determine the misclosure. All benchmarks were then adjusted with the method of "Equal Weight".

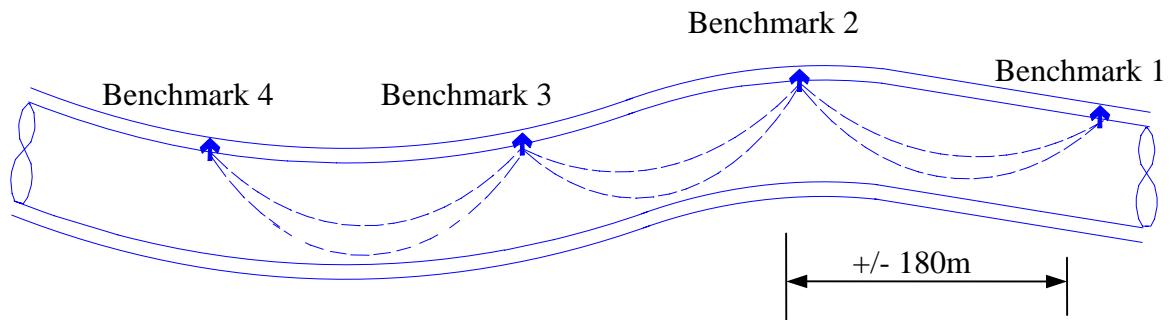

Figure 26 Benchmark looping

The set of control stations and benchmarks come up after the tunnel breakthrough were deemed to be final and would be used for wriggle survey, track work, and electrical and mechanical service layout.

The following survey misclosure was attained at the project.

Breakthrough Date	Location	Survey Misclosure After Tunnel Breakthrough			
		Chainage	Alignment	Accuracy	Level
27-Feb-04	Down Track (1.7Km) Shung Shui to Kwu Tung	15mm in shortage	7mm in shortage north	1 in 10,3000	10mm too high
21-Jun-04	Down Track (1.4Km) Kwu Tung to Chau Tau	5mm in excess	27mm in excess north	1 in 5,1000	3mm too low
23-Dec-04	Up Track (1.7Km) Shung Shui to Kwu Tung	25mm in shortage	30mm in shortage north	1 in 4,4000	5mm too low
08-Apr-05	Up Track (1.4Km) Kwu Tung to Chau Tau	9mm in shortage	10mm in shortage north	1 in 10,4000	6mm too low

Table 2 Summary of survey misclosure

3.6 Dispalcement of Tunnel

The TBM tunnel was more liable to an up/down vertical movement than a left /right horizontal movement as the ring escaped from the shield skin. The movement would be quite significant causing the tunnel to uplift if the annular grouting was not done properly. Also over excavating a tunnel in a soft ground condition would result in the tunnel to settle by it own weight.

A convergance array (Figure 27) in form of the shape of a star was established at critical location not only to monitor the movement of the tunnel but also to detect the deformation of the circular shape of the tunnel.

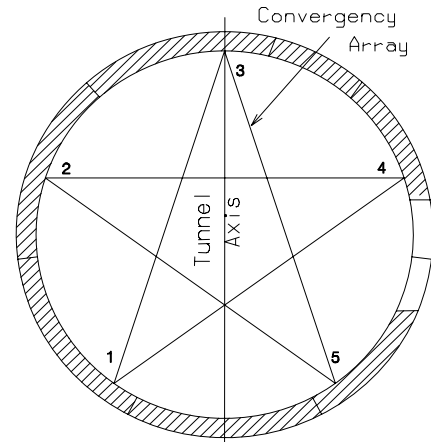

Figure 27 Convergence array

4 CONCLUSION

In this project, a total length of 6.4Km tunnel was laid by the TBM involving four times setting the machine for the break in. The project offered an excellent opportunity for the author to acquire the in-depth knowledge regarding surveying with TBM.

4.1 The Tunnel Guidance System

Despite the tunnel guidance system is claimed to be a total solution to provide positional information of the TBM, a responsible surveyor cannot just accept the result output by the system without making any sound judgment at all. Manual checking of the position of the TBM is mandatory. The result of maunal checking should be in agreement with that of the automatic system. There had been an incident that the inclinometer malfunctioned and the mistaken roll information was made use of to derive the position of the TBM, 16 meters of tunnel went out of construction tolerance subsequently. The fault was caught by a manual survey check two days after the inclinometer was broken down.

4.2 The Double Zigzag Traverse

The author highly recommend the method in running the control stations in the tunnel project. This method could detect the survey gross error, the setup allows each control station to be fixed by four control stations. The merit of the method is that number of the backsight of a station has been increased to four, offering more chance of getting an unobstructed line of sight from one station to the other. Also a number of known stations available on site make the task of fixing a station by the Method of Satellite easier and quicker.

4.3 Construction tolerance

Location	Length of tunnel constructed within the Allowable Construction Tolerance (+/-75mm)	Length of tunnel constructed outside the Allowable Construction Tolerance (+/-75mm)		
		Factor A	Factor B	Factor C
Down Track (1.7Km) Shung Shui to Kwu Tung	1681m (97.5%)	16m	16m	11m
Down Track (1.4Km) Kwu Tung to Chau Tau	1472m (99.7%)	~	~	4m
Up Track (1.7Km) Shung Shui to Kwu Tung	1617m (93.8%)	57m	~	50m
Up Track (1.4Km) Kwu Tung to Chau Tau	1470m (99.9%)	~	~	2m

Table 3

Summary of tunnel constructed with respect to the allowable construction tolerance

Notes: Factor A : Inability to keep the TBM on course in the soft or mixed ground condition

Factor B : Malfunction of the inclinometer.

Factor C : Poor workmanship in ring building.

In average 98% of the tunnel was constructed within the allowable construction tolerance (Table 3), achieving the ultimate objective for the engineering survey in tunnelling.

The infringement of the structure gauge of the train had occurred at those locations exceeding the allowable construction tolerance. The impact was assessed by the railway system group and a relaxation was granted in view of the amount of out of tolerance were minor in nature and were acceptable to the dynamic movement of the train and installation of electrical and mechanical equipments.

The author would like to express his gratitude to the following companies allowing the valuable project information of Lok Ma Chau Spur Line to be used in the article.

- Kowloon Canton Railway Corporation.
- Dragages Hong Kong.
- tacs gmbh - Specialist for Tunnel Guidance Systems.
- Leica Geosystems Ltd., Hong Kong.

REFERENCES

Bickel J. O., et al. 1996 2nd Edition Tunnel Engineering Handbook.
Kolymbas D., 2005, Tunnelling and Tunnel Mechanics.

BIOGRAPHICAL NOTES

Education: B.Sc. at University of Toronto in 1978.

Work Experience: Practiced engineering survey for large-scale construction projects in Canada, Singapore, China and Hong Kong since 1978.

Current Posting: Land Surveyor with Kowloon Canton Railway Corporation.

- Fellow Member of Hong Kong Institution of Engineering Surveyors
- Member of China Society of Geodesy, Photogrammetry and Cartography
- Member of The Institution of Civil Engineers
- Member of Institution of Civil Engineering Surveyors
- Member of The Royal Institution of Chartered Surveyors

CONTACTS

Andrew Hung Shing Lee

Hong Kong Institution of Engineering Surveyors

P.O. Box 79, Tsuen Wan

Hong Kong

Tel. 852+9137-9387

Email. lhsandrew@hotmail.com