

# Optimal Configuration of Standpoints by Application of Laser Terrestrial Scanners

Alojz KOPÁČIK and Michaela KORBAŠOVÁ, Slovak Republic

**Key words:** terrestrial laser scanner (TLS), point position by TLS, point accuracy by TLS, optimal configuration of standpoints by TLS.

## SUMMARY

In engineering surveying we often meet with a requirement of suggestion of such measurement processes, which lead to work rationalization and to cost decreasing. On a base of mathematical theory it is possible to suggest optimal network structures with possibility to predict achieved accuracy by ensuring of maximal economy. With help of optimization methods it is possible to solve besides others also an optimal project of network configuration. Therefore it is important to arrange optimization processes also into the problem of measurements carried out with terrestrial laser systems (TLS). Even if it is relatively new topic, TLS take in geodesy always more important place.

Scanning accuracy is influenced by uncertainties in distance and angle determination as well as uncertainties resulting from point transformation into one block. Accuracy measurement analysis at one standpoint anticipates to the creation of mathematical model of optimal standpoint configuration by application of TLS. By step by step changed angle uncertainties ( $\sigma_\alpha$ ) we determined an influence of distance on 3D point determination. We think that values given by producers can't be real available by practical measurements and therefore we would like to study these accuracy changes in point position. We would like to point at the several aspects, which are important by an optimal configuration project of TLS standpoints.

There were realized particular necessary calculations concerning several variants and causes, which result into the summary 3D graphical interpretation of results. Through calculated set of points with the same uncertainty of point position ( $\sigma_p = 6\text{mm}$ ) for elective mean error of horizontal angle ( $\sigma_\alpha = 0.06\text{mrad}$ ,  $\sigma_\alpha = 0.09\text{mrad}$ ,  $\sigma_\alpha = 0.12\text{mrad}$ ) were rendered B-spline surfaces by using of Surfer 8 software and Microstation SE software.

After drawing of such determined surfaces from individual potential standpoints of scanner we get conjunctions of these surfaces, which create areas with set of points with the same uncertainty in determination of their 3D position from two neighbouring standpoints. On a base of these conjunctions (areas) it is possible to suggest an optimal configuration of TLS standpoints.

In the end of this paper on a base of former analyses there are described suggestions how it is possible to locate suitable scanner standpoint to achieve required accuracy in 3D determination of point position on scanned object.

# Optimal Configuration of Standpoints by Application of Laser Terrestrial Scanners

Alojz KOPÁČIK and Michaela KORBAŠOVÁ, Slovak Republic

## 1. INTRODUCTION

Terrestrial laser systems (TLS) take in geodesy always more important place. It enables non-contact spatial determination of coordinates, spatial modelling and visualisation of arbitrary building objects with considerable speed, accuracy and complexity.

Aim of this paper is on a base of accuracy analysis of spatial point determination from one standpoint to point at several aspects, which are important for optimal configuration project of TLS's standpoints.

## 2. ACCURACY ANALYSIS OF DETERMINATION OF SPATIAL POINT POSITION FROM ONE STANDPOINT

In the next considerations we came out from assumption that TLS work on a base of known spatial polar method, where from measured slope distance, horizontal and vertical angle we obtained spatial coordinates of certain point. For the better understanding of the next considerations we recommend to become familiar with the base principles and processes by application of TLS in (Kašpar, 2003) or (Zámečnicková - Kopáček, 2003).

Scanning accuracy is influenced by uncertainty in determination of distance ( $\sigma_s$ ) and angles (horizontal  $\sigma_\alpha$ , vertical  $\sigma_\beta$ ), as well as uncertainties resultant from point transformation into one unit. In our considerations by step by step angle accuracy variations ( $\sigma_\alpha$ ) we detected an influence of distance on accuracy of determination of spatial point position. All analysis were realised for Cyrax 2500 terrestrial laser scanner (www.cyra.com). Producer gives accuracy of scanned point position 6 mm by 50 m distance. Our suggested analysis has to examine this fact. As a collection of values for testing and verifying of accuracy we used a set of points simulated by grid of 70 m x 70 m x 70 m, where raster spacing is 10 m. Origin of local coordinate system is in scanner standpoint.

By creation of mathematical model for determination of spatial point position and accuracy characteristics we followed Error Theory in matrix form and together we went out from the known processes in Estimation Theory for the second linear model (Kubáčková et al., 1982). By this process we obtained accuracy characteristics in a direction of each coordinate axis ( $\sigma_x, \sigma_y, \sigma_z$ ) and consequently mean position error  $\sigma_p$  and ellipsoid of errors for each point of grid. We realised several approaches (variants). X Variant presented calculation by fixed X-coordinate, Y variant by fixed Y-coordinate and Z variant by fixed Z-coordinate. Within each variant were furthermore realised three various cases, step by step angle accuracy variations  $\sigma_\alpha$ . In the first case are used values of input accuracy characteristics given by

producer (www.cyra.com). In the second case we increased the value  $\sigma_\alpha$  at 50% and in the third at 100%. We wanted to detect how can change an accuracy of determination of spatial point position by influence of these changes of  $\sigma_\alpha$ . We presume that values given by producer don't have to be real achievable by practical measurements and therefore we want to study these accuracy changes in point position. From values of mean position errors in plane of YZ, XZ and XY were interpolated isolines (curves represented places with the same mean position error  $\sigma_p$ ) in Surfer 8 software.

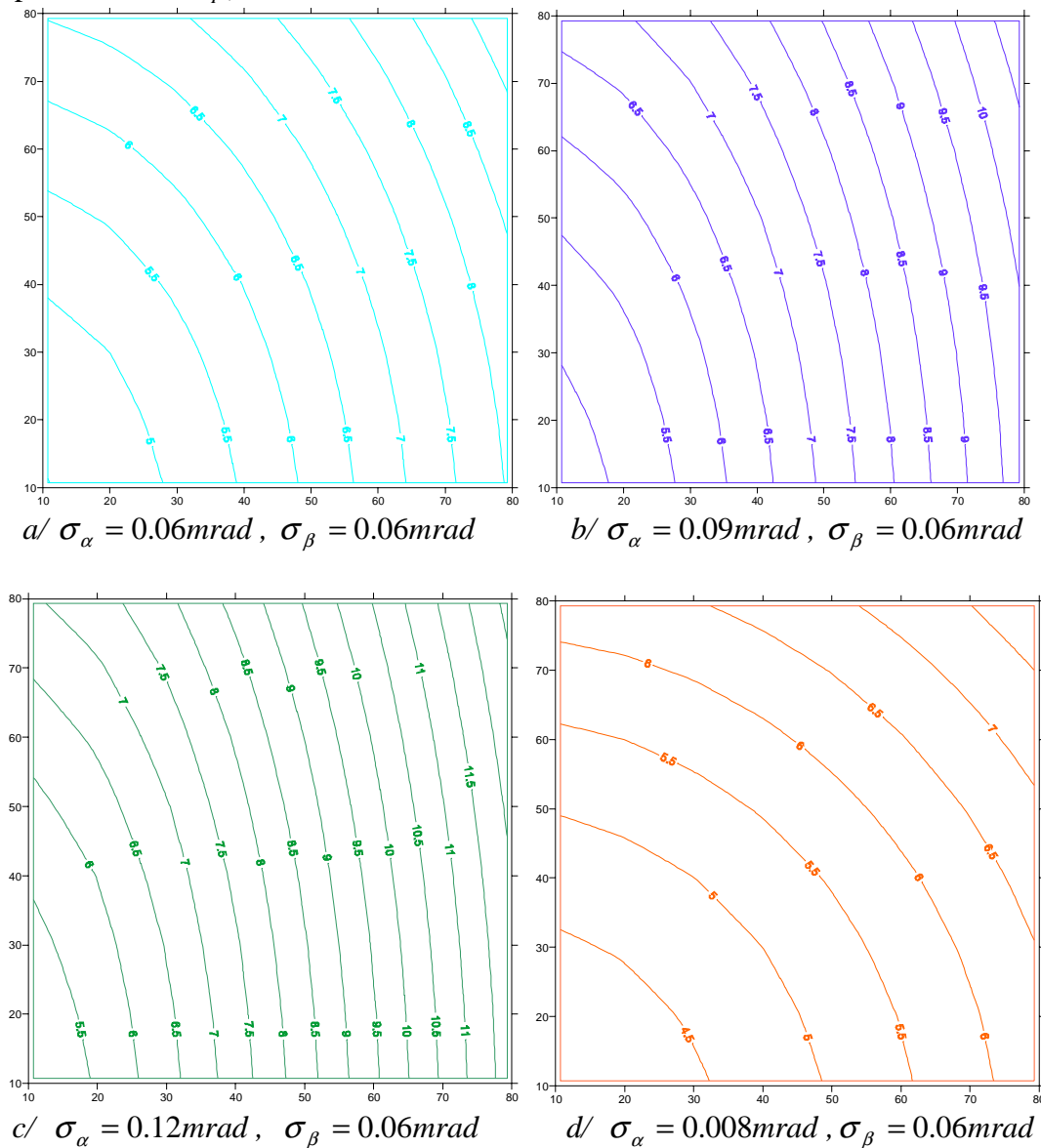

**Fig. 1:** Graphical presentation of  $\sigma_p$  isolines by X-coordinate fixed

For limited range of paper we confine only to graphical interpretation of results by X-coordinate fixed, which is provided on Fig.1a/, 1b/, 1c/. Z-axis rises in a direction of north and Y-axis in a direction of east. From the first three pictures it is visible that isolines of mean position errors create segments of ellipses, eventually ellipsoids. Values of errors vary

in a range of 4.6 mm - 9.4 mm for  $\sigma_\alpha = 0.06\text{mrad}$ , 4.7 mm – 10.9 mm for  $\sigma_\alpha = 0.09\text{mrad}$  and 5.0 mm -12.7 mm for  $\sigma_\alpha = 0.12\text{mrad}$ . To be isolines as circles, it should be valid  $\sigma_\alpha / \sigma_\beta = 1:7$ . (Fig.1d/). By fixing of Y-coordinate values of mean positioning errors vary in a range of 4.2 mm - 9.3 mm for  $\sigma_\alpha = 0.06\text{mrad}$ , 4.3 mm – 10.7 mm for  $\sigma_\alpha = 0.09\text{mrad}$  and 4.5 mm - 12.5 mm for  $\sigma_\alpha = 0.12\text{mrad}$ . The last case is Z-variant. Values of mean positioning errors vary with increasing distance in a range of 4.2 mm – 10.4 mm for  $\sigma_\alpha = 0.06\text{mrad}$ , 4.3 mm – 12.9 mm for  $\sigma_\alpha = 0.09\text{mrad}$  and 4.5 mm – 15.7 mm for  $\sigma_\alpha = 0.12\text{mrad}$ . In this case isolines are partly circle shaped.

### 3. DETERMINATION OF AREA WITH THE SAME MEAN POSITIONING ERROR $\sigma_P$

In the next part we determined coordinates of such points, which have the same uncertainty of 6 mm in point position. By application of Error Theory and modification of formula for mean positioning error we obtain the following formula for distance

$$d = \sqrt{\frac{\sigma_P^2 - \sigma_d^2}{\sin^2 \beta \cdot \sigma_\alpha^2 + \sigma_\beta^2}}, \quad (1)$$

where  $\sigma_P$  is mean positioning error,

$\sigma_\alpha$  is mean error of measured horizontal angle,

$\sigma_\beta$  is mean error of measured vertical angle,

$\beta$  is measured vertical angle.

By step by step change of vertical angle of  $5^\circ$  constant value and by  $\sigma_P = 6$  mm constant value, we determined distances according to the formula (1). Consequently from these values were determined point coordinates. There were realised again three approaches, for  $\sigma_\alpha = 0.06\text{mrad}$ ,  $\sigma_\alpha = 0.09\text{mrad}$  and  $\sigma_\alpha = 0.12\text{mrad}$ . Through set of calculated points we rendered B-spline surfaces in Surfer 8 software and for comparison also in Mircostation SE software. Each of these surface present a set of points with the same mean positioning error  $\sigma_P = 6\text{mm}$  at appropriate standpoint but for selected  $\sigma_\alpha = 0.06\text{mrad}$ ,  $\sigma_\alpha = 0.09\text{mrad}$  and  $\sigma_\alpha = 0.12\text{mrad}$ . Surfaces remind segment of ellipsoid surface. For limited range of paper we again constrained only at a part of graphical presentation of results (Fig.2), (Fig.3).

Such mentioned analysis at individual standpoints precedes an optimization of standpoint's configuration. On a base of mentioned surfaces depicted from various standpoints of scanner and on a base of intersection of these surfaces (which represent places where it is possible to determine a spatial point position with the same accuracy from the two neighboured standpoints) it will be possible to recommend an appropriate optimal configuration of TLS's standpoints.

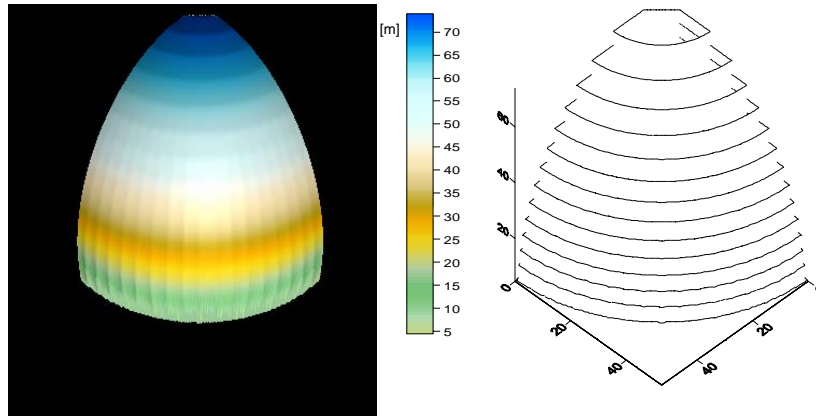

**Fig.2:** Surfaces with the same uncertainty in point position - Surfer 8 software  
 (  $\sigma_{\alpha} = 0.06\text{mrad}$  ,  $\sigma_{\beta} = 0.06\text{mrad}$  )

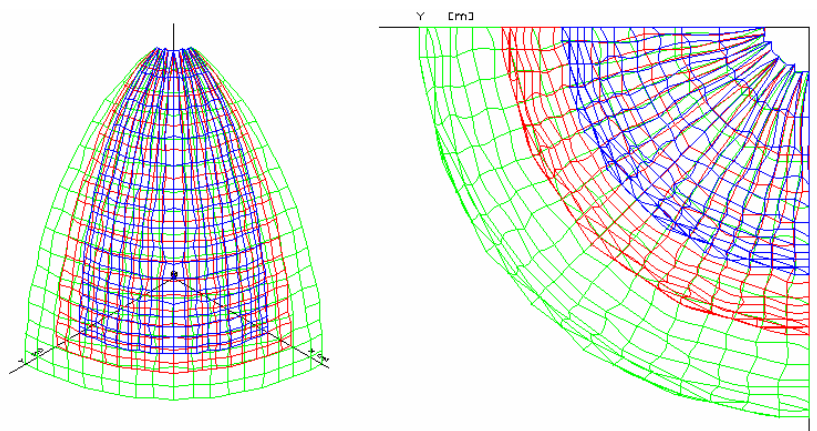

**Fig.3:** Surfaces with the same uncertainty in point position – Microstation SE software  
 -green  $\sigma_{\alpha}=0.06\text{mrad}$ ,  $\sigma_{\beta}=0.06 \text{ mrad}$   
 - red  $\sigma_{\alpha}=0.09\text{mrad}$ ,  $\sigma_{\beta}=0.06 \text{ mrad}$   
 - blue  $\sigma_{\alpha}=0.12\text{mrad}$ ,  $\sigma_{\beta}=0.06 \text{ mrad}$

#### 4. SUGGESTION OF STANDPOINT LOCATION OF TLS IN TERM OF ACCURACY DETERMINATION OF SPATIAL POINT POSITION ON SCANNED OBJECT

On a base of previous analysis in previous chapters is this chapter dedicated to considerations about possible location of TLS's standpoint in term of accuracy determination of spatial point position on scanned object. Because all accuracy analysis in previous chapters concerned to one standpoint of scanner also the next considerations about scanner location are concerning to one standpoint.

On Fig.4a/ there is presented object, which is scanned from the A standpoint (blue coordinate system). The front facade of building is scanned. For better understanding of the next considerations there are two pints P1 and P2 on the front facade, with letters P a L is marked

right and left side of facade and also there are on the figure with help of isolines presented places with the same mean positioning error. From the Fig.4 it is visible that from A standpoint will be point P1 determined with lower accuracy as point P2. It means that the right side of facade is determined with higher accuracy than the left one. In a case that we would like to determine right and left side of facade with the same accuracy in relevant elevation level it will be necessary to remove and rotate A standpoint to B standpoint (red coordinate system). With this process we achieved that isolines of mean positioning errors are approximately parallel with front facade of object (Fig.4a/), it means left and right side of facade in relevant elevation level will be determined with the same accuracy.

In present consideration we achieved determination of point position with the same accuracy within one elevation level (red coordinate system – points P1 and P2 from standpoint B). Now let's have a look at a case when we would like to determine point position with the same accuracy on several elevation levels at the same time. Let's have a better notice on behaviour of blue isolines – standpoint A (Fig.6.7a.) or behaviour of green isolines – standpoint C (Fig.6.7b.). We can see that bottom and upper part of the right side of facade is determined with the same accuracy and also bottom and upper part of the left side of facade is determined with the same accuracy, although right side of facade and left side of facade each other are not determined with the same accuracy. This introduced consideration is possible to document very easily with help of points P3 and P4, which are located on the front side of object facade (Fig. 6.7b.). Point P4, which is situated in one elevation level (in bottom part of facade), is determined with the same accuracy as point P3, which is located in another elevation level (in above part of facade).

As it was above mentioned, all considerations are concerning only one standpoint of scanner. In the next professional activity it will be necessary to realise accuracy analysis for several standpoints of scanner and consequently to suggest optimal configuration of TLS's standpoints.

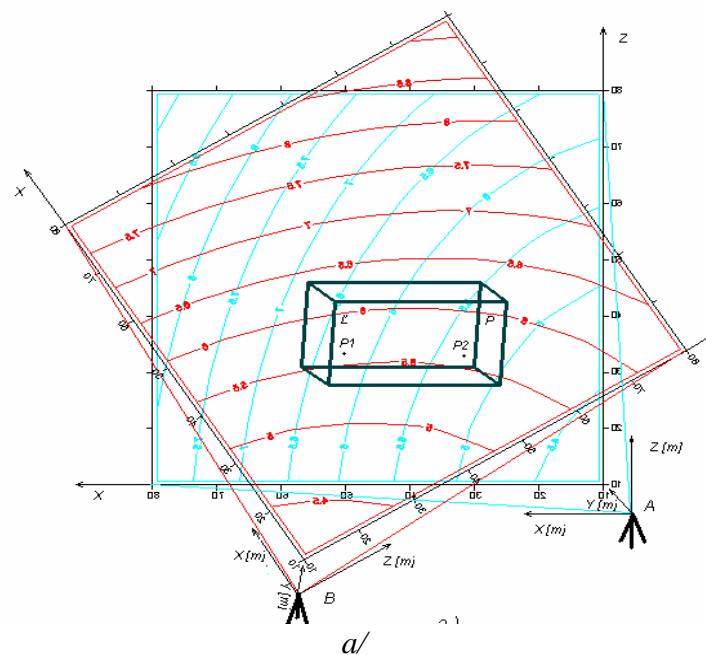

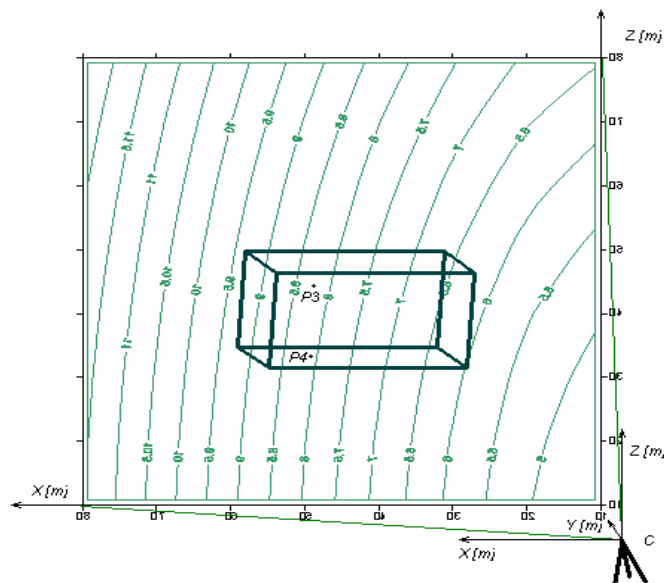

b/

**Fig.4:** Schematic presentation of possible TLS's standpoint location in dependency on required accuracy of point position on scanned object

## 5. CONCLUSION

Aim of this paper was to point at several aspects, which are necessary by suggestion of optimal configuration of TLS's standpoints. There were realised necessary calculations by application of several variants and cases, which resulted in summary 3D interpretation of results. Uncertainty in position of scanned point ( $\sigma_p = 6mm$ ) given by producer to 50 m distance of scanning was with help of our realised accuracy analysis not only confirmed but also it was shown that this distance can be at about approximately 20 metres overdrawn, so it can be at about 70 m. B-spline surfaces rendered through calculated set of points with the same uncertainty of point position ( $\sigma_p = 6mm$ ) for elected variances of horizontal angle ( $\sigma_\alpha = 0.06mrad$ ,  $\sigma_\alpha = 0.09mrad$ ,  $\sigma_\alpha = 0.12mrad$ ), reminded a shape of segment of ellipsoid surface. After drawing of such determined surfaces from individual possible scanner standpoints is possible to get intersections of surfaces, which create areas with point sets with the same uncertainty in determination of its point position from two neighbored standpoints. On a base of these intersections (areas) it is possible to recommend an optimal configuration of TLS's standpoints. We are able to suggest appropriate location of scanner standpoint to be possible to reach required accuracy in determination of point position on scanned object. From above mentioned clearly results that using of optimization processes in TLS technology will be not simple matter and therefore this problem is still opened for further research.

## REFERENCES

- Kubáčková, L. - Kubáček, L. - Kukuča, J. 1982. Probability and Statistics in Geodesy and Geophysics. 327 p., Bratislava, Veda.
- Kašpar, M. et al. 2003. Laser Scanning Systems in Civil Engineering. 90 p., Hradec Králové, Vega Inc.
- Zámečnicková, M. – Kopáček, A. 2003. Terrestrial Laser Systems. In: 11th Slovak Geodetic Days. pp. 1 – 8, Bratislava, Chamber of Surveyors and Cartographers.

## BIOGRAPHICAL NOTES

### **Univ.-Prof. Dr. habil. Alojz Kopáček**

Study Geodesy and Cartography SUT Bratislava 1977-82. Doctoral study at the Department of Surveying at SUT Bratislava in 1982-85. Senior lecturer at the Department of Surveying – lectures and seminars from Geodesy for CE, Geodesy for Water Managers and Construction Engineers, the Underground and Mine Surveying and Engineering Surveying, Measurement Systems in Engineering Surveying and Surveying in Civil Engineering (the study program in English). From 1990 - 1992 lectures and seminars at the TU Vienna from Geodesy and Engineering Surveying. Chairman and member of State Exam and Diploma Commissions at TU Brno, Uni Žilina and at SUT Bratislava and the Slovak Chamber of Surveyors and Cartographers. Member of the European project EEGCES, WG1. Delegate national of the Com.2 (Education) of the FIG. Member of the board of Geodetski list (Croatia) and the WG's of FIG and IAG, which activity is oriented to implementation of laser technology in geodesy. Research in the field of application of TLS and dynamic measurements in real-time, the integrated solutions by increasing the level of automated quantification in measurement. Standardisation, chairman of the TC 89 - Geodesy and cartography (Slovakia), author of 4 ISO standard translations to the Slovak system of standards (STN).

### **Korbašová Michaela, MSc.**

Study Geodesy and Cartography SUT Bratislava 1996-2001. Internal form of doctoral study at STU Bratislava from 2001-2002; continue external form of doctoral study from 2002. Lecturer at the Department of Surveying at SUT from 2002 – Surveying, Surveying in Civil Engineering, Engineering Surveying, Theory of Measured Data Processing. Takes part in solution of grant project VEGA 1/0318/03. Author of several publications in various journals and conference proceedings.

## CONTACTS

Alojz Kopáčik

Slovak University of Technology, Faculty of Civil Engineering, Department of Surveying  
Radlinského 11

813 68 Bratislava

SLOVAK REPUBLIC

Tel. +421 2 5927 4559

Fax + 421 2 5249 4334

Email: [alozj.kopacik@stuba.sk](mailto:alozj.kopacik@stuba.sk)

Web site: <http://www.svf.stuba.sk/kat/GDE/>

Michaela Korbašová

Slovak University of Technology, Faculty of Civil Engineering, Department of Surveying  
Radlinského 11

813 68 Bratislava

SLOVAK REPUBLIC

Tel. + 421 2 59274 391

Fax + 421 2 52494 334

Email: [michaela.korbasova@stuba.sk](mailto:michaela.korbasova@stuba.sk)

Web site: <http://www.svf.stuba.sk/kat/GDE/>